

Instructions for Installation, Operation and
Maintenance of Cutler-Hammer IQ DP-4000
Electrical Distribution System Monitor

TD 17548A



***IQ DP-4000 User Manual
Customer Comments***

Did you find any corrections that need to be made to this manual?
(Please include the page number.)

Were any parts of the manual unclear? Do you require further detail or
description? (Please list parts.)

What are your special application needs?

As part of a constant effort to serve your needs, we are interested in
any information you can supply about your application or use of the IQ
DP-4000. If you would like to share this information, please check the
box below.

Please call me to discuss my use of the IQ DP-4000.

Name _____ Title _____

Company _____ Phone _____

Street and Number _____

City _____ State _____ ZIP _____

Information Request

Please send me updated application materials when available.

Please send me information on

Please have a Sales Engineer call.

Please contact me to discuss IMPACC Local Area Network applications.

Name _____ Title _____

Company _____ Phone _____

Street and Number _____

City _____ State _____ ZIP _____

USING THE MANUAL

This manual covers the installation, setup, operation, maintenance, and troubleshooting of the IQ DP-4000. It gives step-by-step instructions for programming the IQ DP-4000 to meet your specific application requirements.

If you are installing the IQ DP-4000 for the first time, you should read and become familiar with the following sections of the manual:

1. Introduction
2. Hardware Description
3. Operator Panel
4. Installation and Startup
5. Programming the IQ DP-4000
6. Maintenance and Troubleshooting Maintenance

If you are replacing an IQ Data Plus II with an IQ DP-4000, you should read and become familiar with the following sections of the manual:

1. Introduction, Section 1.3, Upgrading From the IQ Data Plus II
2. Troubleshooting and Maintenance, Section 6.3. The instructions for removing and replacing the IQ Data Plus II are the same as for removing and replacing the IQ DP-4000.

SAFETY PRECAUTIONS AND LIABILITY INFORMATION

PRELIMINARY COMMENTS AND SAFETY PRECAUTIONS

This Technical Document covers all aspects of installation, operation, and unit-level maintenance of the IQ DP-4000. This document is a guide only for authorized and qualified personnel who select and use the IQ DP-4000. Please refer to the specific Warning and Caution in this section before proceeding. If you require further information regarding a particular installation, application, or maintenance activity, contact your Cutler-Hammer Representative.

Warranty and Liability Information

No warranties, expressed or implied, including warranties of fitness for a particular purpose of merchantability, or warranties arising from course of dealing or usage of trade are made regarding this information, recommendations, and descriptions contained herein. In no event will Cutler-Hammer be responsible to the purchaser or user in contract, in tort (including negligence), strict liability, or otherwise for any special, indirect, incidental, or consequential damage or loss whatsoever, including but not limited to damage or loss of use of equipment plant or power system, cost of capital, loss of power, additional expenses in the use of existing power facilities, or claims against the purchaser or user by its customers resulting from the use of the information and descriptions contained herein.

Safety Precaution

All safety codes, safety standards, and/or regulations must be strictly observed in the installation, operation, and maintenance of this device.

WARNING

THE WARNINGS AND CAUTIONS INCLUDED AS PART OF THE PROCEDURAL STEPS IN THIS DOCUMENT ARE FOR PERSONNEL SAFETY AND PROTECTION OF EQUIPMENT FROM DAMAGE. AN EXAMPLE OF A TYPICAL WARNING LABEL IS SHOWN ABOVE IN REVERSE TYPE TO FAMILIARIZE PERSONNEL WITH THE STYLE OF PRESENTATION. THIS WILL HELP TO ENSURE THAT PERSONNEL ARE ALERT TO WARNINGS WHICH MAY APPEAR THROUGHOUT THE DOCUMENT. IN ADDITION, CAUTIONS ARE ALL UPPER CASE AND BOLDFACED AS SHOWN BELOW.

CAUTION

COMPLETELY READ AND UNDERSTAND THE MATERIAL PRESENTED IN THIS DOCUMENT BEFORE ATTEMPTING TO INSTALL, OPERATE OR USE THE EQUIPMENT. IN ADDITION, ONLY QUALIFIED PERSONS SHOULD BE PERMITTED TO PERFORM ANY WORK ASSOCIATED WITH THE EQUIPMENT. ANY WIRING INSTRUCTIONS PRESENTED IN THIS DOCUMENT MUST BE FOLLOWED PRECISELY. FAILURE TO DO SO COULD CAUSE PERMANENT EQUIPMENT DAMAGE.

Factory Correspondence

Contact the Advanced Product Support Center(APSC) at 1-800-809-2772 if you have any questions about operating or troubleshooting the IQ DP-4000.

1.1 INTRODUCTION

The IQ DP-4000 is a microprocessor-based monitoring and protective device that provides electrical metering and system voltage protection. This device is a compact, self-contained, panel-mounted device designed to replace numerous individual meters, relays, and recorders. The IQ DP-4000 is available in four models - 4010, 4030, 4110, and 4130. Table 1.A compares the models' features.

Model	Power Module	I/O
4010	Separate Source	No
4030	3-Phase	No
4110	Separate Source	Yes
4130	3-Phase	Yes

Table 1.A Model Comparison

The IQ DP-4000 measures:

- AC Line Current (each phase)
- AC Line to Line Voltage
- AC Line to Neutral Voltages (for 4 wire systems)
- Watts
- Vars
- VA
- Power Factor (apparent and displacement)
- Demand (Watts, Vars, VA, Currents)
- Frequency
- %THD (currents and voltages)
- Watt-hours
- Var-hours
- VA-hours

The IQ DP-4000 monitors the ac line feeding a specific load or loads and detects conditions that exceed your chosen parameters. In all cases, it detects the following listed conditions. If equipped with the optional I/O module (models 4110 and 4130), it can protect the loads against:

- Undervoltage
- Overvoltage
- Current Phase Loss
- Voltage Phase Loss
- Phase Reversal
- Phase Unbalance

Voltage may be directly monitored on 3-phase AC lines within a range of 120 to 600 VAC nominal without external potential transformers and within a range above 600VAC to 510 KV with external potential transformers (PTs). Current monitoring is through external current transformers (CTs) with ratios between 5/5 to 12,800/5.

Typical applications for the IQ DP-4000 are:

- Incoming 3-Phase AC lines
- Transformer feeder circuits
- Branch circuits
- Motor starters
- 3-Phase electrical loads

The device will automatically display the appropriate unit value (in Units, Kilo-Units, or Mega-Units) of the item displayed on the screen. The values have a floating decimal point.

The program directing the monitoring function is permanently stored in the IQ DP-4000. The setpoints you choose are also retained by the non-volatile EEPROM memory.

The non-volatile memory of the IQ DP-4000 will save a snapshot of all metered values just after an alarm condition. The IQ DP-4000 can store two alarm conditions at the same time. You can view the snapshot for each alarm, and record the values before or after resetting the unit.

The operator panel, the unit's front faceplate, has a display window that indicates the actual value of the selected item. The Display Window also indicates the cause of the detected alarm signal.

You choose and enter the individual setpoints by setting the setpoint switches. You can easily program the device in the field because you do not need a specialized programming language. With the new Setpoint Switch design, you can program the unit to handle a large number of current transformer and voltage transformer ratios.

1.2 REQUIRED USER-SUPPLIED HARDWARE

In all instances, it is recommended that the IQ DP-4000 use three user-supplied external current transformers, with 5 amp secondaries, for metering current functions. In retrofit cases, where only two current transformers are provided, refer to the sample wiring diagrams (Figures 4.4 - 4.15).

Note: A 2 CT arrangement will work, but will not detect a current phase loss on L2.

For voltages above 600V, you must supply potential transformers to step down the voltage to match the

maximum allowable voltage permitted by the unit. See Table 5.F for the voltage ranges that the IQ DP-4000 monitors.

1.3 UPGRADING FROM THE IQ DATA PLUS II

The IQ DP-4000 replaces the IQ Data Plus II (DP II). The IQ DP-4000 features all the monitor and display parameters of the DP II and also adds:

- Metering of VA, Var-hours, VA-hours, and %THD
- Optional I/O module
- Min/Max for voltages, current, and power
- Demand/Peak Demand
- Max % THD (currents and voltages)
- Metering parameters with an active alarm condition present
- Expanded IMPACC functionality
- Increased range and resolution for metered parameters

For backward compatibility with existing IMPACC systems, the IQ DP-4000 features an IQ Data Plus II communications mode which formats all buffers as if the product were a Data Plus II. This is the default communications mode when the unit is manufactured. See Section 5.14 to change this setpoint.



FOR FULL BACKWARD COMPATIBILITY, ALL SETPOINTS MUST CORRESPOND WITH AN EXISTING VALID DPII SETPOINT. SEE TD 17271 FOR DATA PLUS II SETTINGS. THE WIRING IS IDENTICAL WITH THE EXCEPTION OF THE SEPARATE SOURCE POWER MODULE TERMINALS. NOTE THAT NO JUMPERS ARE REQUIRED FOR 120/240 VOLT SELECTION.

1.4 REPLACEMENT PARTS

Refer to Table 1.B for a list of available parts and accessories for the IQ DP-4000. For ordering information, contact your local Cutler-Hammer distributor.

Description	Catalog Number	Style Number
IQ DP-4000 with 3-phase power module without I/O module	IQDP4030	4D13110G01
IQ DP-4000 with separate source power module without I/O module	IQDP4010	4D13110G02
IQ DP-4000 with 3-phase power module with I/O module	IQDP4130	4D13110G03
IQ DP-4000 with separate source power module with I/O module	IQDP4110	4D13110G04
3-phase power module	IQA3PPM	8793C15G01
Separate source power module	IQASSPM	8793C07G01
36" extension cable	IQACABLE	2107A55G02
45" extension cable	IQA45CABLE	2107A55G03
IQ mounting flange	IQFLANGE	5743B02G01
Communication module	IPONI	8793C36G01
IQ DP-4000 Auxiliary Power Supply	IQDPAUXPS	5743B37G01
IQ DP-4000 Configuration Utility (setpoint programming aid)	See the Cutler-Hammer website at www.cutlerhammer.eaton.com	

Table 1.B Parts and Accessories

2.1 INTRODUCTION

The IQ DP-4000 is designed for mounting through a cutout in a panel (usually a cabinet face or door). The hardware description is divided into the following:

- Operator Panel
- Rear Access Area
- User-Supplied External Hardware
- Optional Communications (IMPACC) Module

2.1.1 Operator Panel

The operator panel, the front face of the IQ DP-4000, is accessible from the outside of the panel or door into which it is mounted and allows you to:

- Monitor the actual metered values on the display window
- Determine which metered value is being displayed
- Step through the list of metered items
- Determine that an alarm condition exists
- Determine the cause of the alarm condition
- Reset the unit after an alarm condition
- View and reset minimum and maximum values from the faceplate
- Reset energy

See Section 3 for a detailed description of the operator panel.

2.1.2 Rear Access Area

You can access the rear of the IQ DP-4000 by opening the door onto which it is mounted. Make all wiring connections to the unit from the rear of the chassis. Figure 2.1 shows the rear of the chassis and includes:

1. The 3-Phase AC line connections to the voltage terminal block at the bottom of the power module.
2. The current transformer terminal block at the top of the chassis connects to the required external current transformers.
3. The Alarm 1/Alarm 2 terminal block connects to controlled, external devices (with the optional I/O module only).

4. Setpoint Switches, located on the rear right side of the chassis, allow you to tailor each IQ DP-4000 model for your specific applications. For a complete description of each Setpoint Switch setting see Section 5.
5. The power module is available as a separate source power module (Models 4010, 4110) and as a 3-Phase power module (Models 4030, 4130).

The Power Module for the IQ DP-4000 is mounted on the rear of the chassis when shipped, but can be detached and moved up to 45 inches (91.44 cm) away using an optional ribbon cable (Style No. 2107A55G03) if local codes prevent AC power devices from being located on the cabinet door.

Figure 2.1 The Three-Phase Power Module for

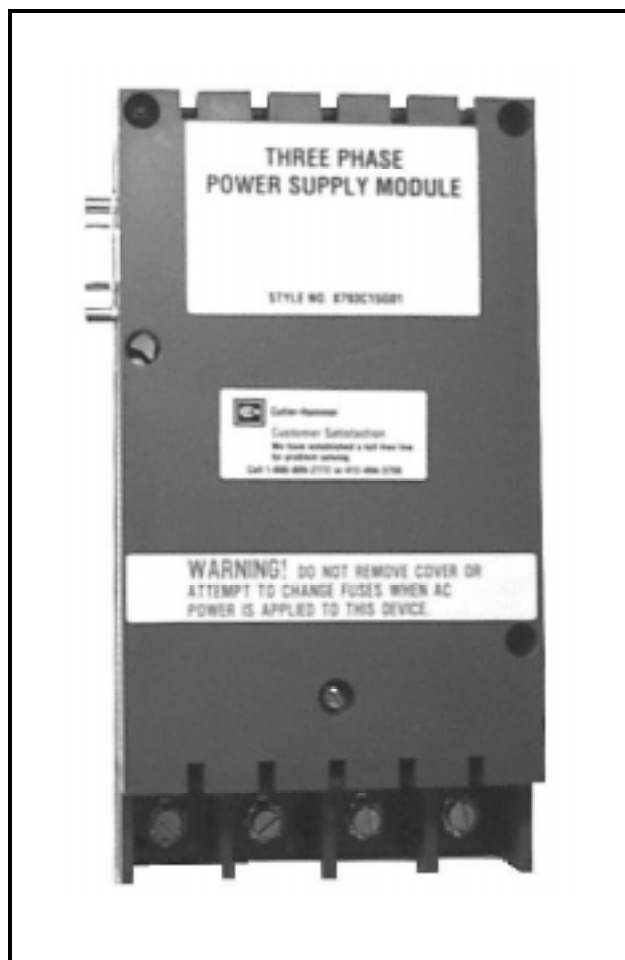

Models 4030 and 4130

Note: The Separate source power supply can be powered by 96-264VAC or 100-350VDC.

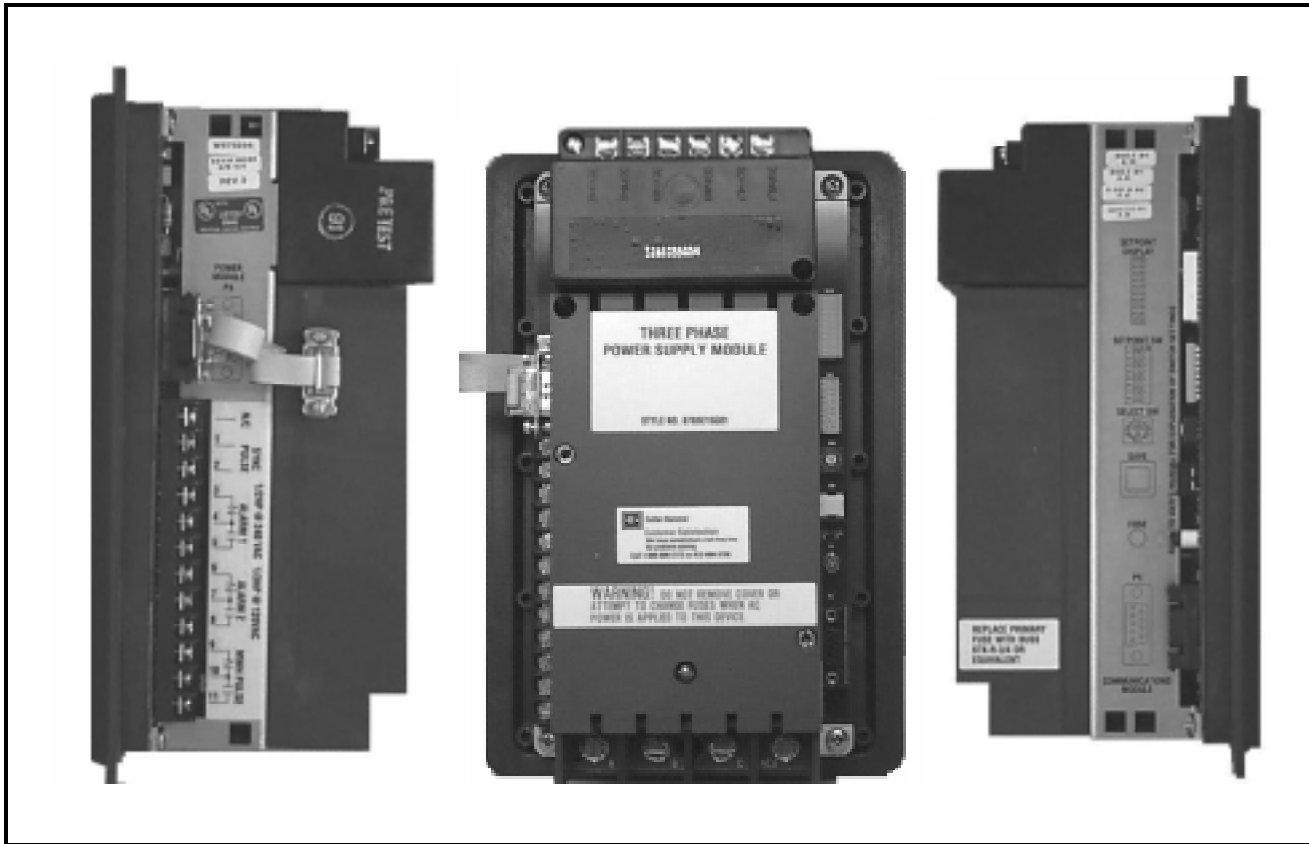

Figure 2.2 Rear Access Area of Chassis

⚠ WARNING

REMOVE ALL VOLTAGE FROM THE IQ DP-4000 BEFORE REMOVING AND/OR REPLACING THE FUSES.

6. A fuse, internal to the power module, is located in series with each of the 3 incoming AC lines. The fuses are 3/4 amp, 600 volt, 200kA interrupting rating. These fuses are internal to the power module. You can access them by removing the three screws holding the cover in place (see Figures 2.2 and 2.3).

7. A fuse, external to the power module, is located on the rear right of the chassis. This fuse is a 1/4 amp fuse to protect the 24V on Terminal Block 1 for the Discrete input.

Required: The voltage terminal block has four terminals for wiring (one is neutral). The neutral must be connected to Neutral or Ground depending on your configuration.

8. The communication port, located on the lower right chassis, is designed to connect with the optional communication module (a PONI module). See Section 2.1.4 for a detailed description.

9. The discrete input can be configured to be either a reset input or a sync pulse input. The input is activated by a contact closure across terminal block contacts 1 and 2. See Section 5.15.1 for configuring this input.
10. Watt-hour Pulse. The Watt-hour pulse initiator is a set of contacts that completes a circuit and sends a pulse signal to an external pulse recorder. You can program the amount of energy between pulses using Setpoint Switches (see Section 5.15.3). The pulse initiator is a KYZ output, meaning the relay will change state for each pulse.

2.1.3 User-Supplied External Hardware

The IQ DP-4000 requires you to wire at least 2, and up to 3 current transformers into the CT terminal block from an external location (see Figures 4.4 - 4.15). These are user-supplied and must have a 5 amp secondary. Potential transformers are required only for voltages above 600 V and are wired directly to the AC line connection terminals.

2.1.4 Optional Communications Module

The IQ DP-4000 is an IMPACC-(Integrated Monitoring Protection and Control Communications) compatible device. IMPACC can remotely monitor, control and program the IQ DP-4000 when it is equipped with the optional communications module. An IPONI is typically mounted on the back of the power module and connects to the IQ DP-4000 via the communications port on the lower right side of the rear of the chassis.

IMPACC is a noise immune communications system that permits communications from the IQ DP-4000 to a master computer via a high frequency carrier signal over a shielded twisted pair of conductors. The conductors can extend up to 10,000 feet without using repeaters. The INCOM (Industrial Communications) chip allows communications between IMPACC compatible devices, and accounts for the system's high degree of reliability.

Functions available remotely through the communications option are:

- Monitoring and trending of displayed values and device status
- Device programming
- Min/Max values
- *Cause of alarm* information

2.1.4.1 IMPACC Series III Software

Series III Software provides the ability to monitor and record power distribution system data as it occurs.

Series III is a Microsoft™ Windows-compatible application featuring user-friendly, menu-driven screens with easy set-up and operation. Additional features include:

- System/device alarm logging and reporting
- Gateway interface for connectivity to other information networks
- Data trending

2.1.4.2 IMPACC Enhanced Graphics

Enhanced Graphics software provides the capability to generate custom animated color graphics. For example, animated one-line drawings of electrical power distribution systems, flow diagrams of processes, equipment elevation view, and other graphical representations can be developed.

2.1.4.3 IMPACC Connectivity

An IMPACC network or computer running Series III software can interface with other networks. Examples of IMPACC connectivity interfaces include:

- PLCs (Programmable Logic Controllers)
- DCSs (Distributed Control Systems)
- BMSs (Building Management Systems)
- PC-based graphical operator interface programs

2.2 SPECIFICATIONS

This section covers the following specifications:

- General Specifications (Table 2.A)
- Protection Function Specifications (Table 2.B)
- Metering specifications (Table 2.C)

2.2.1 General Specifications

The IQ DP-4000 meets the following specifications:

Function	Specifications
Power Requirement	PT Burden (3-Phase power module) 10VA PT Burden (separate source

	power module) 0.02 VA CT Burden 0.003 VA
Frequency	50/60 Hz
Line Characteristics	Nominal Line $\pm 20\%$
Operating Temperature	-20° to 70°C (-4° to 158°F)
Storage Temperature	-30° to 85°C (-22° to 185°F)
Humidity	5 to 95% RH non-condensing
Fuses	1/4 ampere 3/4 ampere, 600 volts, Buss Type KTK-R-3/4 (3 required).
Alarm/WH Contact Ratings	10 amps @ 120/240 VAC (Resistive) 10 amps @ 30 VDC (Resistive)

Table 2.A General Specifications

2.2.2 Protective Function Specifications

You can individually select each of the protection functions to initiate an alarm on any, all, or no functions. A short description of each of the protection functions follows:

- Voltage phase loss. A Voltage phase loss is detected when the amplitude of any single phase is less than 50% of the nominal amplitude.
- Current phase loss. A Current phase loss is detected when the current amplitude of the smallest phase is 6.25% of the current amplitude of the largest phase.
- Phase Unbalance. A phase voltage unbalance is detected when the difference between the largest and smallest line-to-line voltages exceeds the percentage of nominal line voltage by a factor of 5, 10, 15, 20, 25, 30, 35, or 40%. (The Setpoint Switch position determines the % factor.) Phase Reversal. A phase reversal is detected if a phase sequence different from that which was programmed (ABC or CBA) is detected.

- Overvoltage. An overvoltage is detected when the amplitude of the AC line voltage exceeds 105, 110, 115, 120, 125, 130, 135, or 140% of the nominal line voltage. (The Setpoint Switches determine the % factor.)
- Undervoltage. An undervoltage is detected when the amplitude of the AC line voltage falls below 95, 90, 85, 80, 75, 70, 65, or 60% of the nominal line voltage. (The Setpoint Switches determine the % factor.)

All protected functions update every 1.4 seconds with a 60 Hz line, or every 1.5 seconds with a 50 Hz line.

Protection Function	Description
Voltage Phase Loss	Any phase less than 50% of nominal
Current Phase Loss	Smallest phase less than 6.25% of largest phase
Phase Unbalance	Line voltage \pm nominal in ranges from 5 to 40%
Phase Reversal	Absolute monitoring
Overvoltage	Range 105 to 140%
Undervoltage	Range 95 to 60%
Alarm Delay	Range 1 to 20 seconds
Reset Delay	Range 1 to 120 seconds

Table 2.B Protection Function Specifications

2.2.3 Metering Specifications

Table 2.C shows the metering specifications for the IQ DP-4000.

Item	Displayed through IMPACC	Local Display
AC Amperes Phases A, B, C	+/- 0.3%	+/- 0.3% +/- 1 digit
AC Voltage Phase A-B, B-C, C-A	+/- 0.3%	+/- 0.3% +/- 1 digit
Phase A-N, B-N, C-N	+/- 0.3%	+/- 0.3% +/- 1 digit
Watts	+/- 0.6%	+/- 0.6% +/- 1 digit
Vars	+/- 0.6%	+/- 0.6% +/- 1 digit
VA	+/- 0.6%	+/- 0.6% +/- 1 digit
Watt-hours	+/- 0.6%	+/- 0.6% +/- 1 digit
Var-hours	+/- 0.6%	+/- 0.6% +/- 1 digit
VA-hours	+/- 0.6%	+/- 0.6% +/- 1 digit
Power Factor	+/- 1 %	+/- 1 %
Frequency	+/- 0.1Hz	+/- 0.1 Hz
% THD	Through 31st Harmonic	

Table 2.C Metering Specifications

Accuracy is maintained from 3% to 250% of the full scale of the device.

Nominal Full Scale Current: 5 Amps ac

Nominal Full Scale Voltage: 120-600 Vac

Certification

- UL: Listed UL-508, File E62791, NKCR Auxiliary Devices
- NEMA: 3R, 12 (when gasketed)
- FCC: Part 15, Class A

3.1 INTRODUCTION

This section describes the operator panel of the IQ DP-4000. The discussion of the operator panel contains the following sections:

- pushbuttons
- display window
- LEDs

The operator panel is shown in Figure 3.1

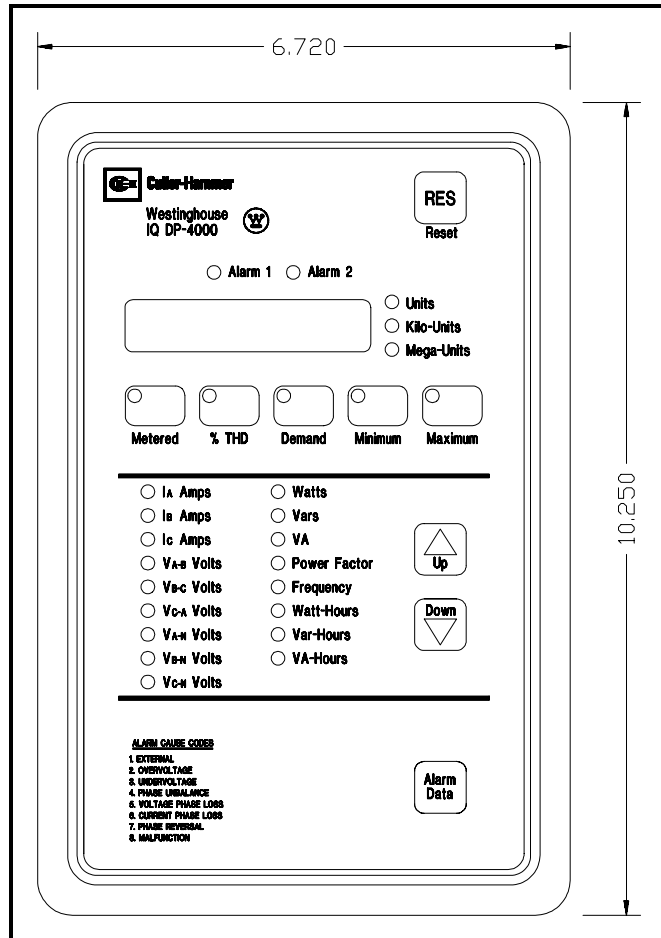

Figure 3.1 Operator Panel

3.1.1 Pushbuttons

The operator panel has nine membrane pushbuttons. They are:

- **Reset.** After an alarm event, the Reset pushbutton allows you to reset the alarms. The Reset pushbutton is the red button marked RES, located in the upper right-hand corner of the faceplate.
- **Up/Down Step Display.** The Up/Down pushbuttons step through the items that the IQ DP-4000 monitors. If you press the Up and the Down buttons

at the same time, the INCOM network address for your unit appears in the Display Window. It monitors the following items:

- I_A Amps
- I_B Amps
- I_C Amps
- V_{A-B} Volts
- V_{B-C} Volts
- V_{C-A} Volts
- V_{A-N} Volts
- V_{B-N} Volts
- V_{C-N} Volts
- Watts
- Vars
- VA
- Power Factor (apparent and displacement)
- Frequency
- Watt-Hours
- Var-Hours
- VA-Hours

Each time you press the Up or Down pushbuttons, the LED to the left of the selected item illuminates. At the same time, the present operating value corresponding to that item is in the display window.

- **Alarm Data pushbutton.** The Alarm Data pushbutton, located on the bottom right of the operator panel, allows you to toggle between Alarm 1, Alarm 2, and presently metered values. A blinking LED indicates you are viewing the snapshot (data saved at the time an alarm condition occurred for that particular alarm. An LED that is constantly illuminated indicates an active alarm condition for that particular alarm. (Please note that the Alarm LED will always blink when being viewed, even for an active alarm).

If you press the Alarm Data button before there has been an alarm condition, no light appears beside the Alarm.

- **Monitor pushbuttons.** The Monitor pushbuttons, located in a row just below the LED display window are:

- Metered. The Metered pushbutton displays the metered values for all the parameters on the Operator Panel.
- %THD. This button displays Percent Total Harmonic Distortion for the amps and volts for each phase.
- Demand. The Demand button displays the demand current for each phase, as well as the demand Watts, Vars, and VA.
- Minimum. This button displays the minimum values for all currents and voltages as well as Watts, Vars, VA, Power Factor (apparent and displacement) and Frequency. You can view and reset this value from the faceplate.
- Maximum. This button displays the maximum values for all currents and voltages as well as Watts, Vars, VA, Power Factor (apparent and displacement) and Frequency. You can view and reset this value from the faceplate.
- Stepup and Stepdown. Holding the Stepup and Stepdown pushbuttons will display the INCOM address(only if the PONI module is attached and communication has been established with Series III).
- Minimum and Maximum pushbuttons. Holding the Maximum and Minimum pushbuttons simultaneously will display the version of firmware the device is currently using. This is useful when troubleshooting the device.

Note: The Metered, %THD, and Demand pushbuttons can work with the Minimum and Maximum pushbuttons to display minimum and maximum metered values, maximum % THD, and maximum peak demand.

- Pushbutton combinations.
 - Reset and Metered. Holding the Reset and Metered pushbuttons simultaneously for three to four seconds will reset minimum and maximum values for all metered parameters. This will cause the display to blank, and the Metered LED to blink. When the display is restored, the Metered Min/Max values have been reset.
 - Reset and %THD. Holding the Reset and the %THD pushbuttons simultaneously for three to four seconds will reset maximum values for all %THD parameters. This will cause the display to blank, and the %THD LED to blink. When the display is restored, the Maximum %THD values have been reset.
 - Reset and Demand. Holding the Reset and the Demand pushbuttons simultaneously for three to four seconds will reset maximum values for all Demand parameters. This will cause the display to blank, and the Demand LED to blink. When the display is restored, the Maximum Demand values have been reset.

3.1.2 Display Window

The IQ DP-4000 has a large, easy to read 6-digit LED display window that shows the value for the associated Monitor pushbuttons, the values for the protective functions and the alarm cause codes. The display window is at the top of the faceplate, just below the Alarm LEDs.

3.1.3 LEDs

The Operator Panel LEDs are divided into four types:

- Monitor LEDs
- Parameter LEDs
- Units LEDs
- Alarm LEDs

3.1.3.1 Monitor LEDs

At any given time, one or more of the LEDs associated with a Monitor pushbutton is illuminated. Each one identifies which monitor item is currently displayed. The Monitor LEDs are part of the Monitor pushbuttons and are labeled:

- Metered
- %THD
- Demand
- Minimum
- Maximum

3.1.3.2 Parameter LED's:

The LEDs that monitor the following conditions will blink in response to several monitoring situations:

Note: The following examples assume that the unit is using the mathematic sign convention.

- Watts, Vars and/or Power Factor. The selected LEDs blink when viewing reverse power flow, lagging (negative) Power Factor, and negative Vars. The LEDs do not blink if the values are positive (leading). Refer to Figures 3.2, 3.3, 3.4 and 3.5 for further explanation.
- Induction Motor Loads. Typically when monitoring induction motor loads the power flow is in Quadrant 4. The Watts are positive and the Power Factor is lagging. By definition, the Power Factor and Vars are negative and the LEDs will blink for these two values. Refer to Figure 3.2.
- Power Factor Correction Capacitors. When monitoring a load that also has Power Factor correction capacitors and/or leading Power Factor synchronous motors so that the new load is capacitive, then the power flow is in Quadrant 1. In this case, none of the LED's will blink.
- Power Distribution. Typically you will encounter three conditions when monitoring power distribution (Refer to Figure 3.5):
 1. Breakers A and B are closed and C is open. Power flow is in Quadrant 4. The Power Factor and Vars will be negative and the respective LED's will blink.
 2. Breakers A and C are closed and B is open. Power flow for Breaker A and C is in Quadrant 4. The Power Factor and Vars will be negative, and the LED's will blink for Power Factor and Vars readings.
 3. Breakers B and C are closed and A is open. The power flow for Breaker B is in Quadrant 4 and the metering condition is the same as Conditions 1 and 2. However, the power flow for Breaker C is reversed and is in Quadrant 2. Only the Watts LED and Power Factor LED will blink.

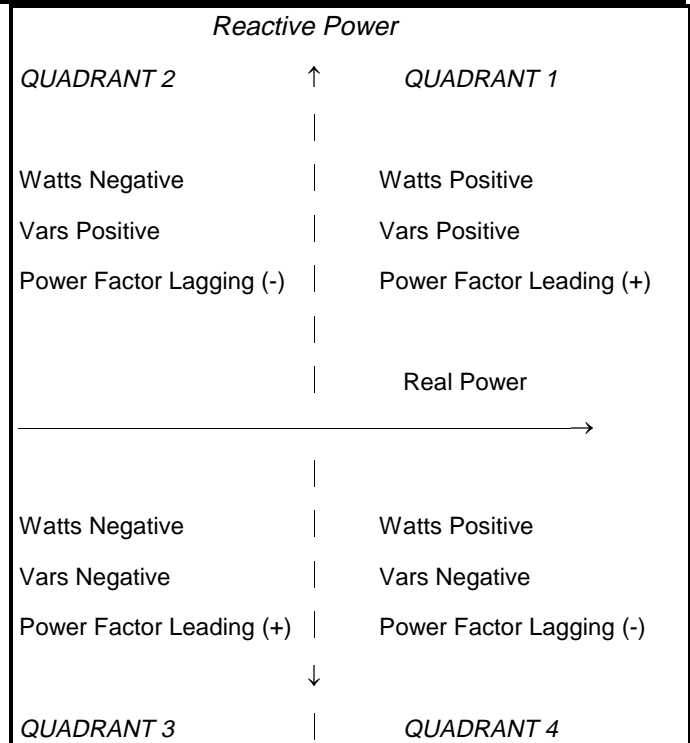

Figure 3.2 Power Quadrants, Mathematical

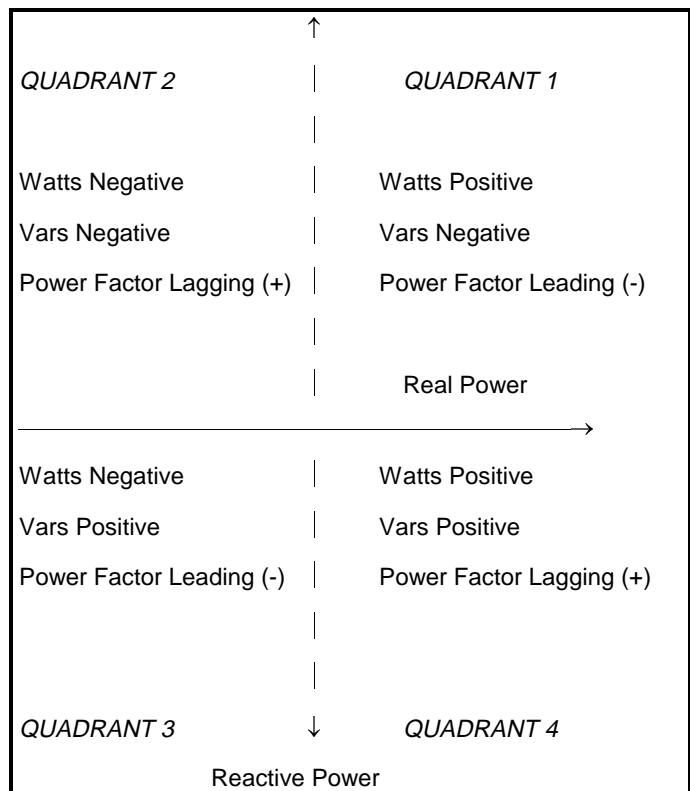

Figure 3.3 Power Quadrants, Power Engineer's Sign Convention

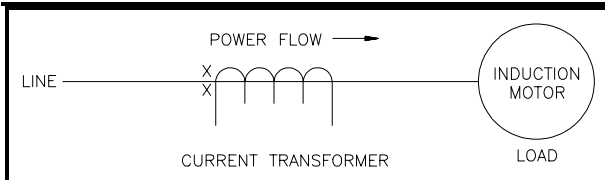

Figure 3.4 Induction Motor Load

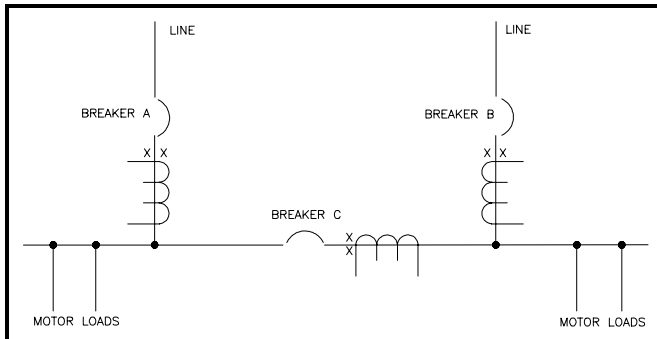

Figure 3.5 Power Distribution

Note: Refer to section 5.11 VAR/Power Factor Sign Convention Setpoint for more information about + and - values.

3.1.3.3 Units LEDs: Auto Range Units for Monitoring

The units for monitoring are Units, Kilo-Units, and Mega-Units. Figure 3.1 shows the location of these LEDs to the right of the display window. These units are fixed, based on your selection for PT and CT ratios so that the display is consistent with the PT and CT sizes. They let you know the measurement unit for the displayed function.

3.1.3.4 Alarm LED's

The Alarm LEDs, (Alarm 1, Alarm 2) when continuously lit, indicate that an alarm condition exists. If there is an alarm condition when you press the Alarm Data button, the corresponding LED blinks and the display window shows a digit, from 1 to 8. This digit represents the specific type of alarm condition that is occurring for the selected alarm. The alarm cause codes are listed at the bottom of the faceplate for easy reference. Table 3.A describes the alarm codes by number.

Alarm Cause Code	Operator Panel Designation	Description
1	External	Remote device initiates alarm
2	Overvoltage	An alarm condition occurs
3	Undervoltage	
4	Phase Unbalance	
5	Voltage Phase Loss	
6	Current Phase Loss	
7	Phase Reversal	
8	Malfunction	Internal

Table 3.A Alarm Codes

4.1 INTRODUCTION

This section provides the information for installing the IQ DP-4000 into a metal cabinet door, and performing initial startup. Before beginning installation, be sure to read and understand both this section and Section 2, Hardware Description.

Installing the IQ DP-4000 includes four steps:

1. Mounting the IQ DP-4000
2. Mounting the power source separately from the IQ DP-4000 (if necessary)
3. Wiring the IQ DP-4000
4. Starting the unit for the first time

WARNING

DO NOT HIGH-POT OR MEGGER THIS DEVICE

4.2 PANEL PREPARATION AND MOUNTING THE IQ DP-4000

The IQ DP-4000 is typically mounted on a metal cabinet door. To install the device you must:

- Cut an opening in the door
- Mount the unit

4.2.1 Cutout, Clearances

Before mounting the IQ DP-4000 you must prepare the cutout location. Figure 4.1 shows the chassis cutout dimensions and the location of the ten mounting holes. Before cutting the panel, be sure that the required 3-dimensional clearances for the IQ DP-4000 chassis allow mounting in the desired location (Figure 4.1 shows height and width dimensions, while Figure 4.2 shows depth dimensions.)

When you make the cutout and place the holes for the mounting screws, you must hold relatively tight tolerances. In particular, the horizontal dimension between the center of the mounting holes and the vertical edge must be within +0.050 (0.13 cm) -0 inches.

4.2.2 Mounting

Place the IQ DP-4000 through the cutout in the panel, making sure that the operator panel faces out. When you attach the IQ DP-4000 to the door with the supplied screws, start the screws from inside the panel so they go through the metal door first. If you are mounting the unit on a single-thickness panel, use 0.5 inch (1.2 cm) long screws (included with the IQ DP-4000). The IQ DP-4000 has ten places to attach the unit to the door. The holes

are not threaded, but do not use a tap because this removes excess plastic from the holes, which leaves less threaded material for securing the IQ DP-4000 to the mounting panel.

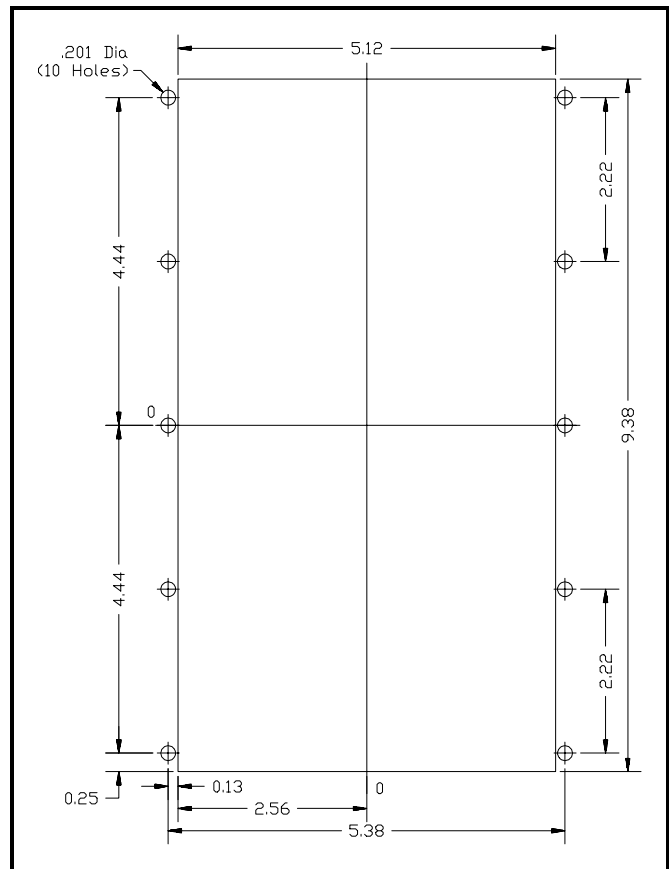

Figure 4.1 Chassis Cutout Dimensions

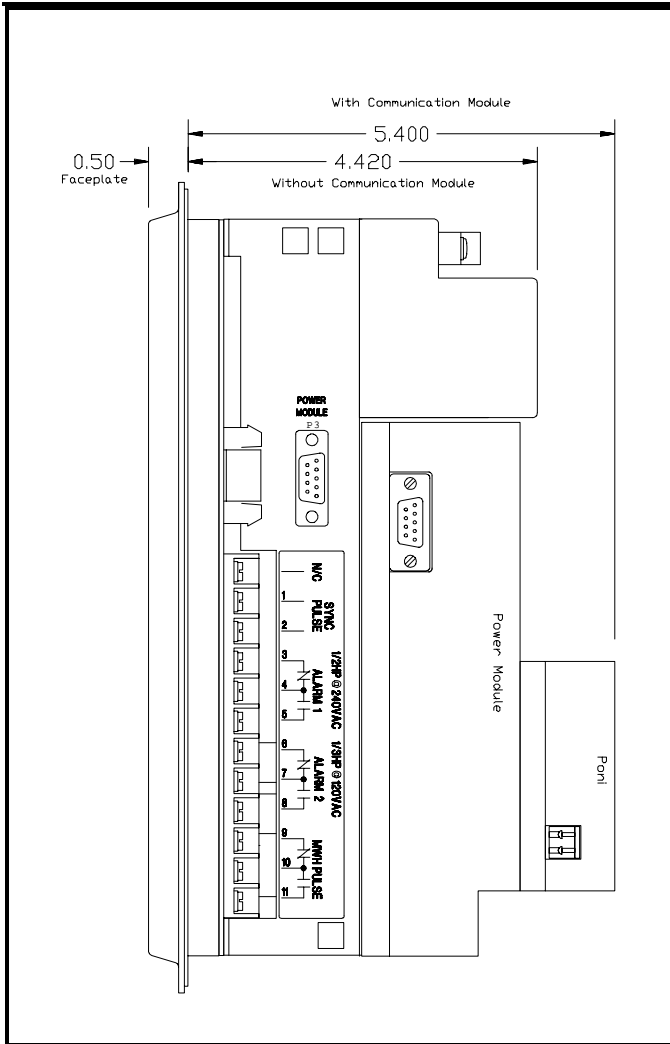

Figure 4.2 Side Profile Depth Dimensions

4.3 MOUNTING THE POWER SUPPLY MODULE SEPARATELY (OPTIONAL)

The IQ DP-4000 uses one of two power modules, a 3-Phase power module or a separate source power supply module:

- A 3-Phase power module (Models 4030 and 4130) receives its power from the same source it monitors. The advantage is that the IQ DP-4000 does not need a separate power source to run.
- The IQ DP-4000, equipped with a separate source power supply module (Models 4010 and 4110), receives power from a source other than the one it monitors. The advantage to this style is that if there is a loss of power to the monitored system, the IQ DP-4000 will not lose power. You may mount either power module separately from the chassis. If you do, check that:
 - The location allows for a cable connection between the IQ DP-4000 chassis and the

power module using either the 36 in. (91.4 cm) or the 45 in. (114.25 cm) Extension Cable Option

- The separated power module can physically fit in the desired location (See clearance dimensions in Figure 4.3)
- To separate the power module from the IQ DP-4000, remove the two screws that secure it to the IQ DP-4000. Use the power module as a drilling template at the new location. Remount it in the properly drilled and tapped holes, using the two 8-32 screws.

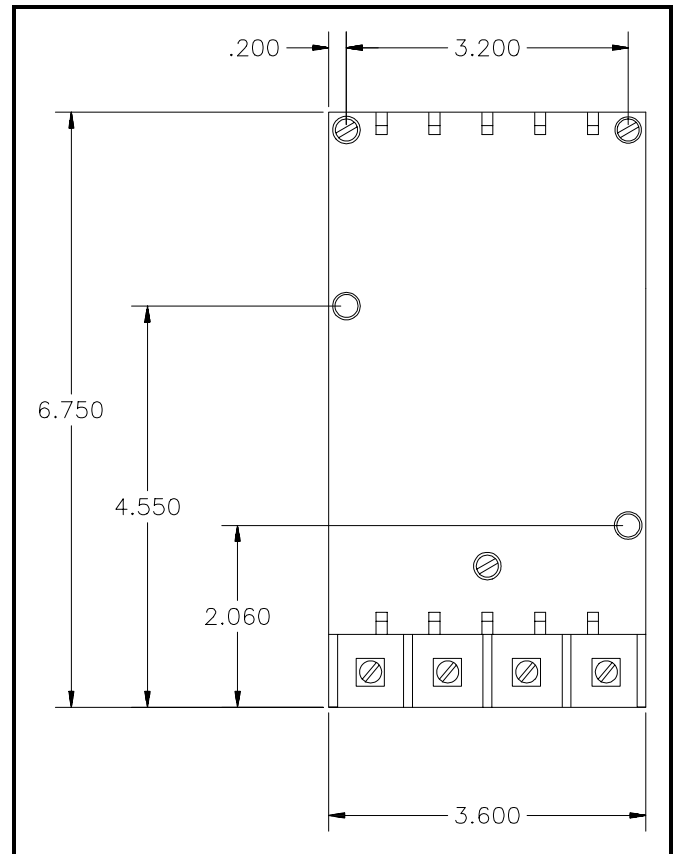

Figure 4.3 Power Module Dimensions

4.4 WIRING

When you wire the IQ DP-4000, you must follow a suitable wiring plan drawing. A wiring plan, created either by you or your OEM, describes all electrical connections between the IQ DP-4000 and the machine or process equipment. All wiring must conform to applicable federal, state, and local codes.



ENSURE THAT THE INCOMING AC POWER AND ALL 'FOREIGN' POWER SOURCES ARE TURNED OFF AND LOCKED OUT BEFORE PERFORMING ANY WORK ON THE IQ DP-4000 OR ITS ASSOCIATED EQUIPMENT. FAILURE TO OBSERVE THIS PRACTICE CAN RESULT IN SERIOUS OR EVEN FATAL INJURY AND/OR EQUIPMENT DAMAGE.

Figures 4.4 - 4.15 show typical wiring plans. When referring to the figures, note the following:

1. Phasing and polarity of the AC current inputs and the AC voltage inputs and their relationship are critical to the correct operation of the wattmeter.
2. The incoming AC line phases A, B, and C connect from three external potential transformers (PT's) to the AC line connection terminals on the chassis (above 600V).

3. You can use NO and NC contacts from the Relays to control external devices. These contacts are rated at 10 amps for 120/240 VAC or 30 VDC.
4. The wires connecting to the IQ DP-4000 must not be larger than AWG No. 14. Larger wires will not connect properly with the various terminal blocks.
5. Keep the wiring between the current transformers and the IQ DP-4000 as short as possible (200 feet max.). Whenever possible, route these lines away from other AC lines and inductive devices. If the lines must cross other AC lines, cross them at right angles.
6. The protective functions of the IQ DP-4000 (with the optional I/O module) directly control the Relays, as described in Section 5.
7. Connect the sync pulse terminals to the dry contact input only. The 24VDC is supplied by the IQ DP-4000 on Terminal 1.

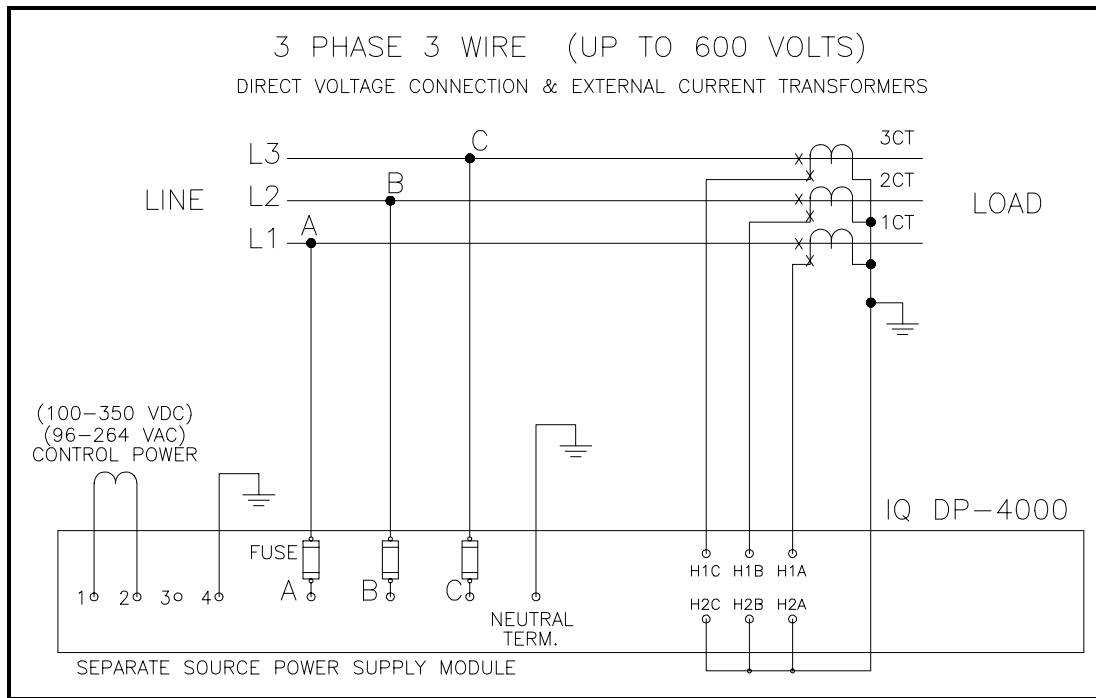

Figure 4.4 3-Phase, 3 Wire (up to 600 volts) Wiring Diagram (Separate Source)

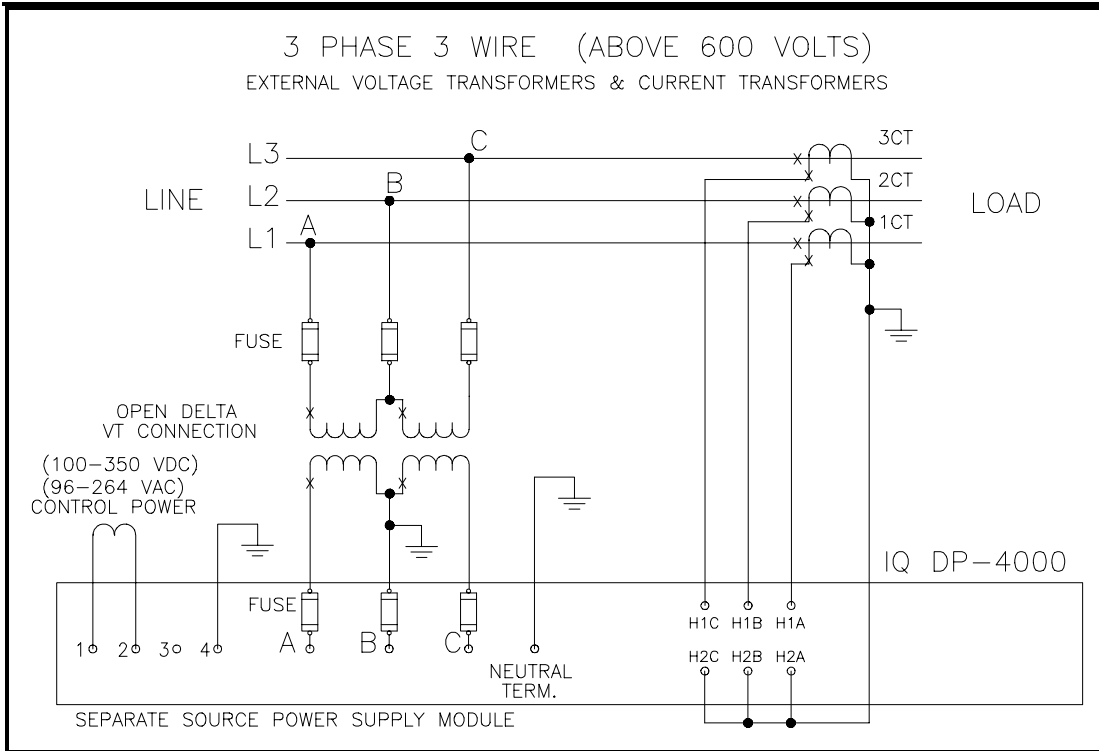

Figure 4.5 3-Phase, 3-Wire (above 600 volts) Wiring Diagram (Separate Source)

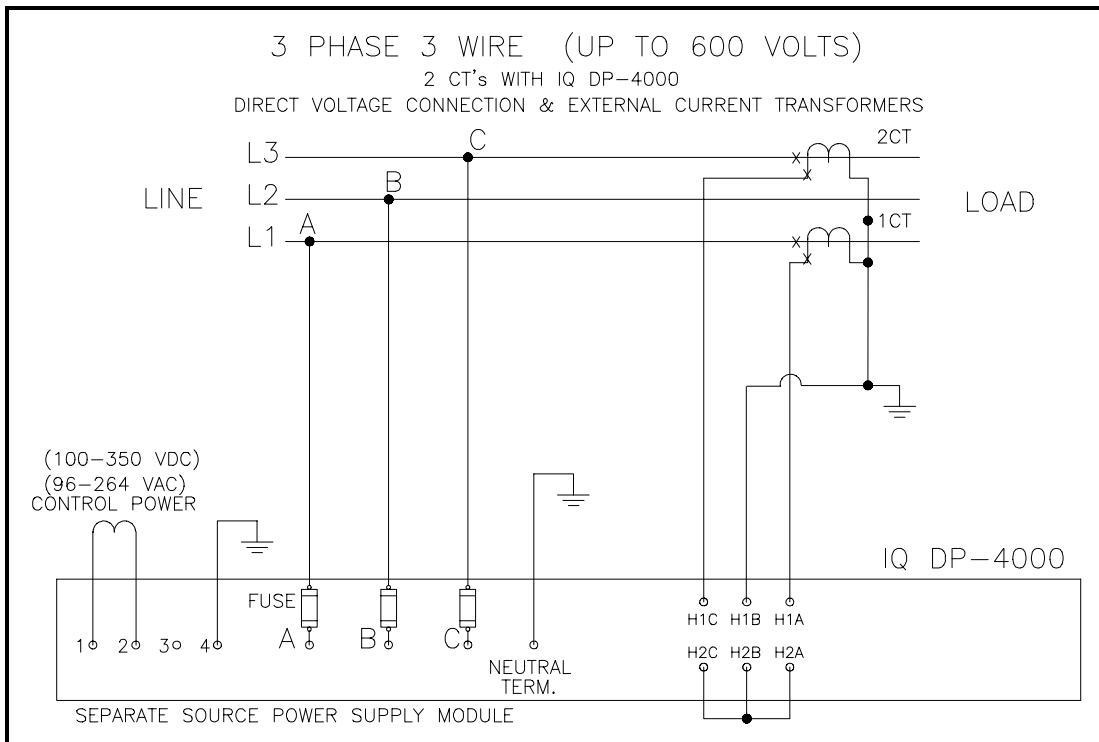

Figure 4.6 3-Phase, 3-Wire (up to 600 volts) Wiring Diagram (Separate Source, 2 CTs)

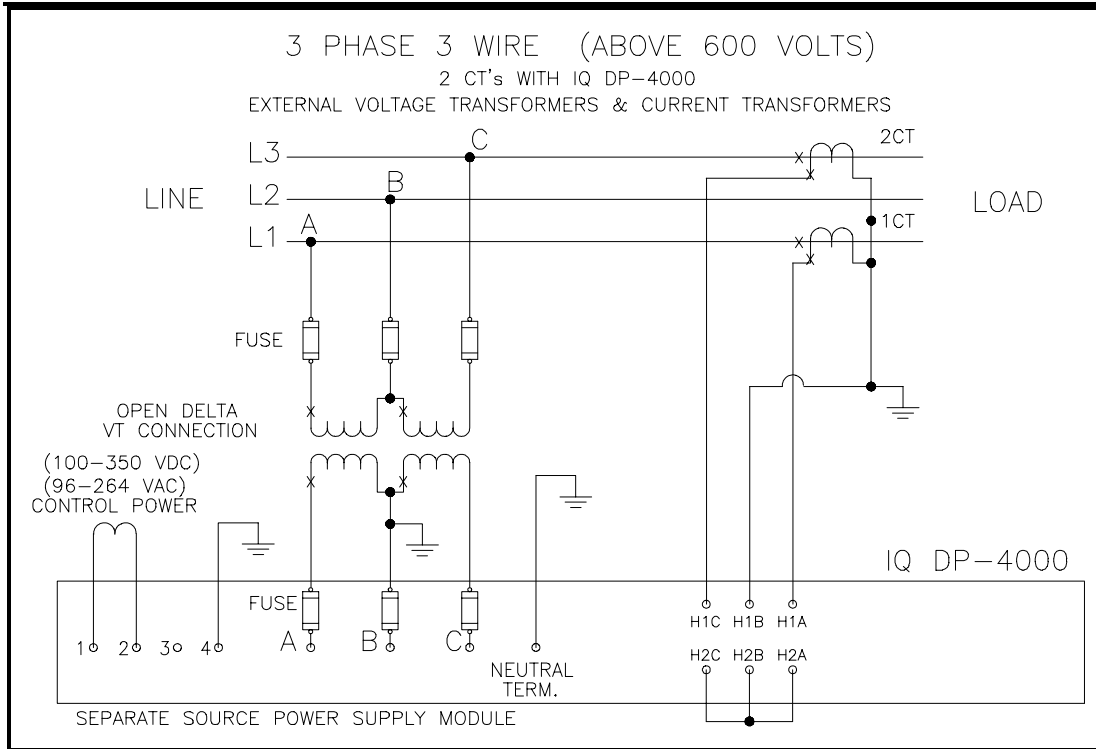

Figure 4.7 3-Phase, 3-Wire (above 600 volts) Wiring Diagram (Separate Source, 2 CTs)

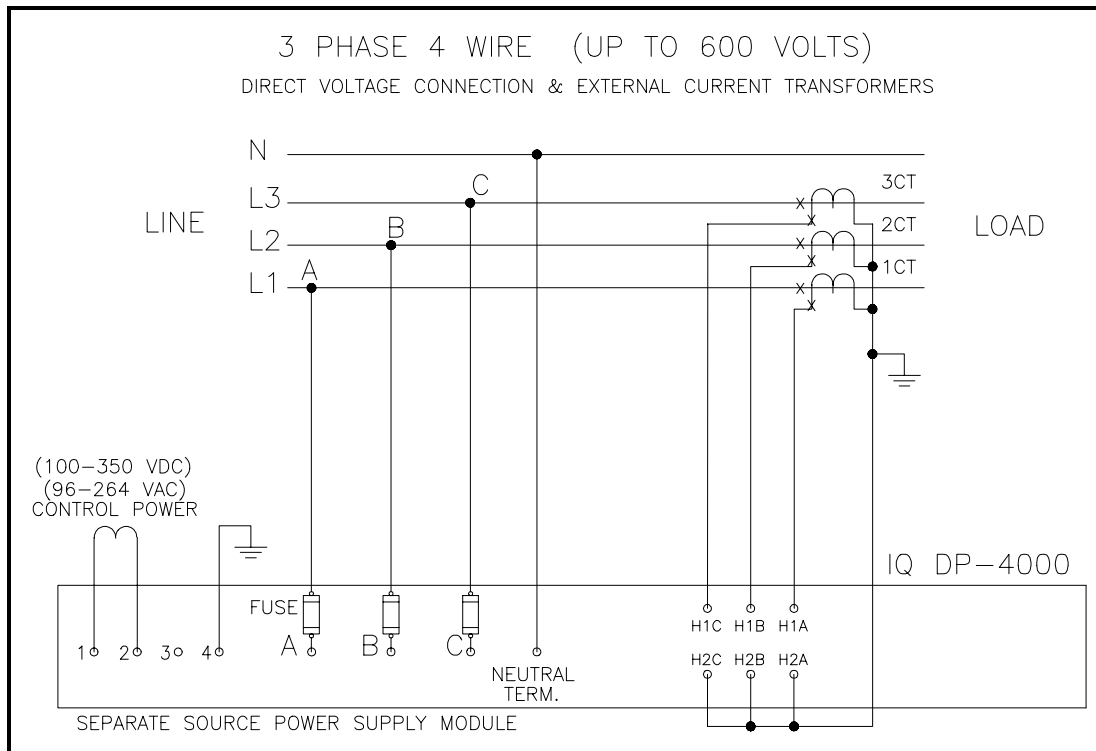

Figure 4.8 3-Phase, 4-Wire (up to 600 volts) Wiring Diagram (Separate Source)

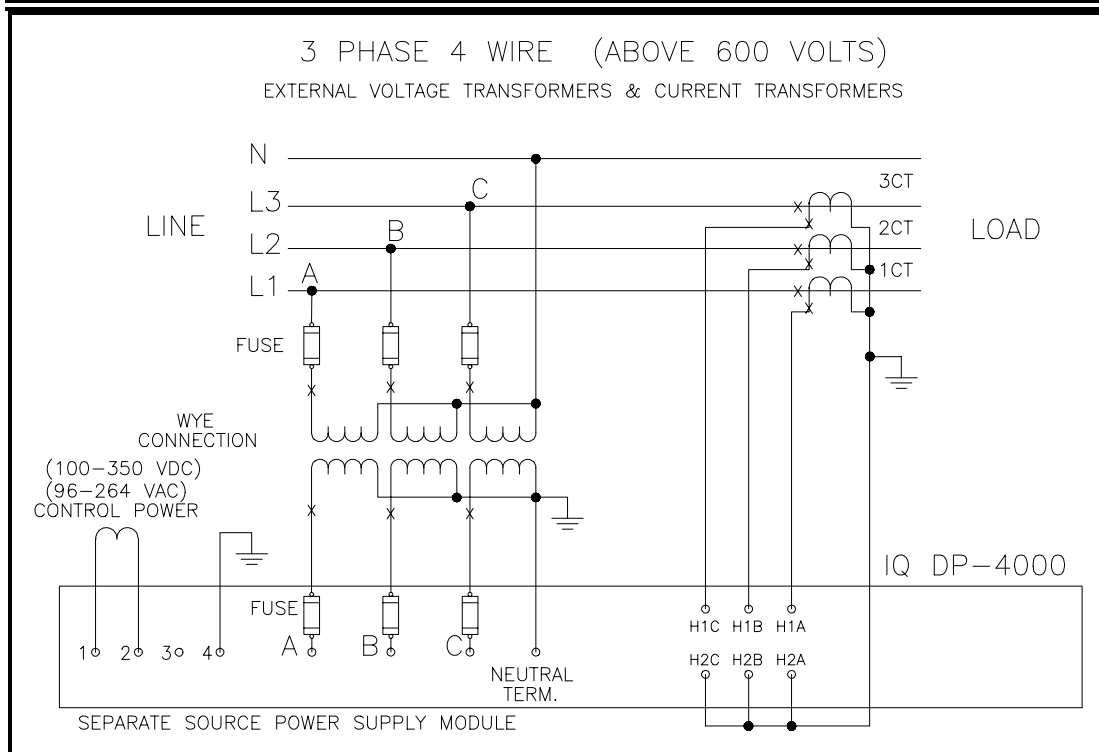

Figure 4.9 3-Phase, 4-Wire (above 600 volts) Wiring Diagram (Separate Source)

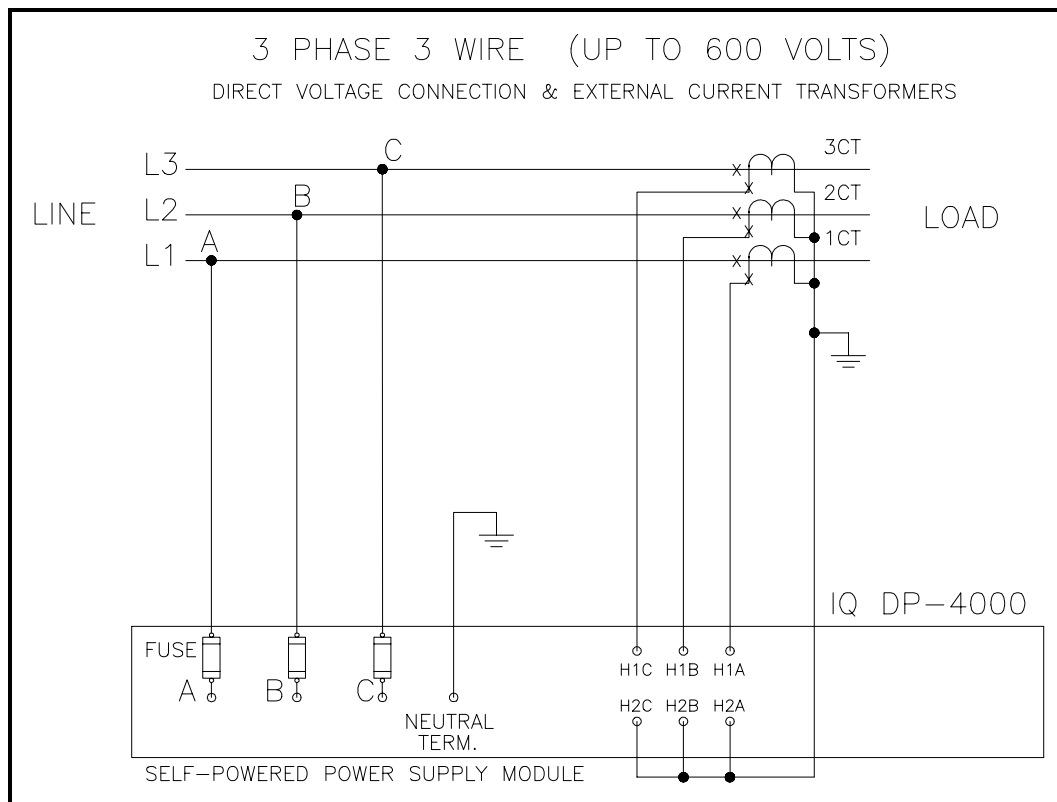

Figure 4.10 3-Phase, 3-Wire (up to 600 volts) Wiring Diagram

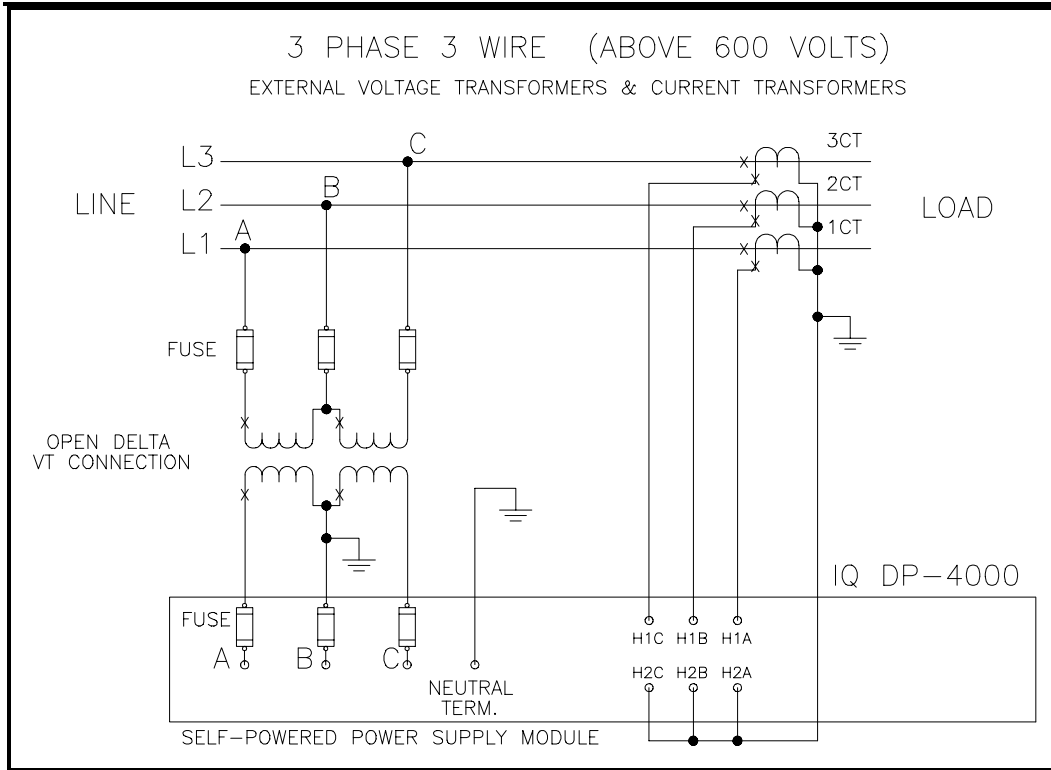

Figure 4.11 3-Phase, 3-Wire (above 600 volts) Wiring Diagram

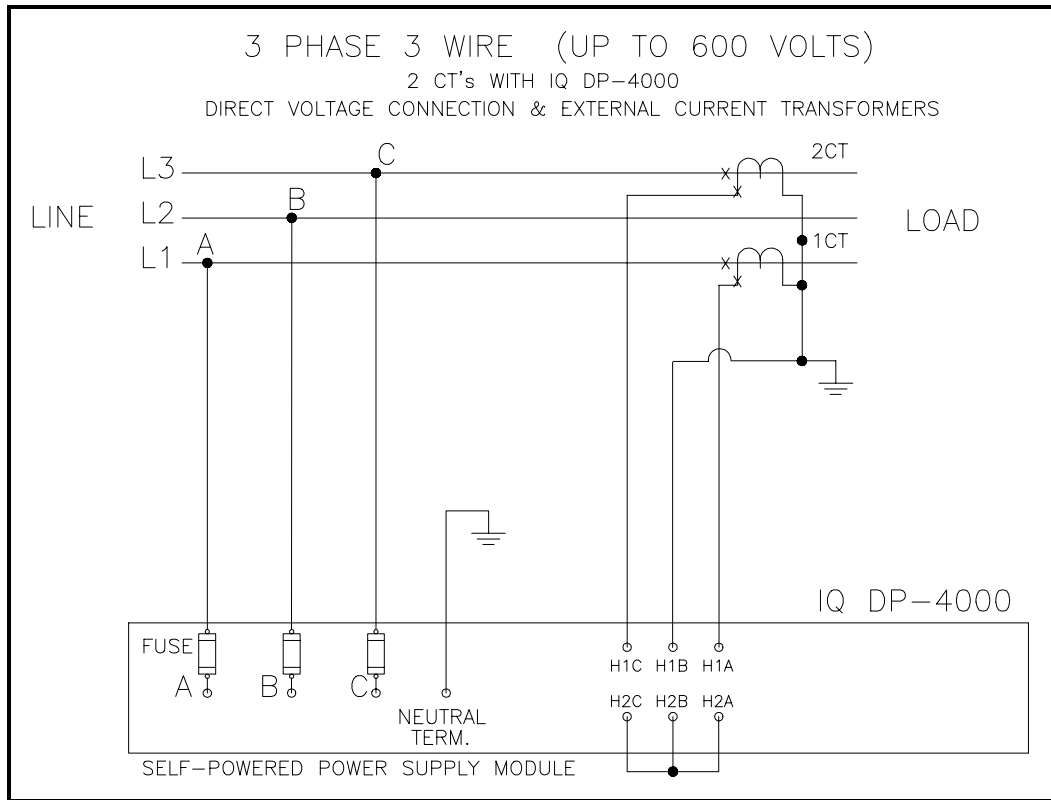

Figure 4.12 3-Phase, 3-Wire (up to 600 volts) Wiring Diagram (2 CTs)

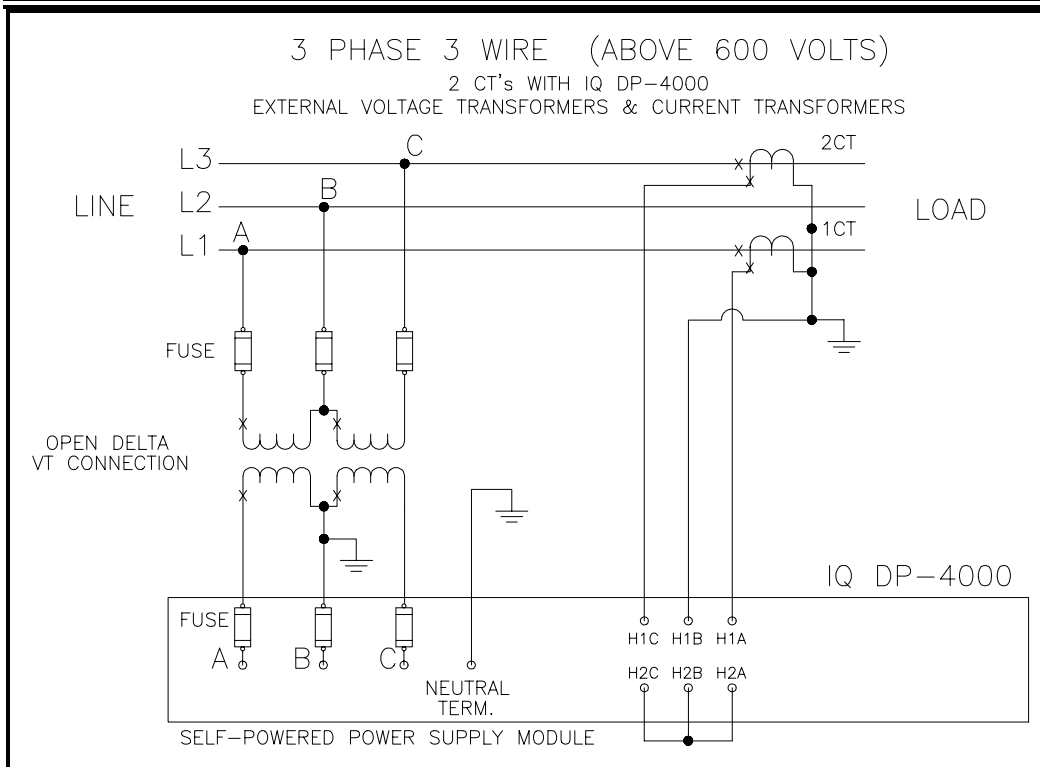

Figure 4.13 3-Phase, 3-Wire (above 600 volts) Wiring Diagram (2 CTs)

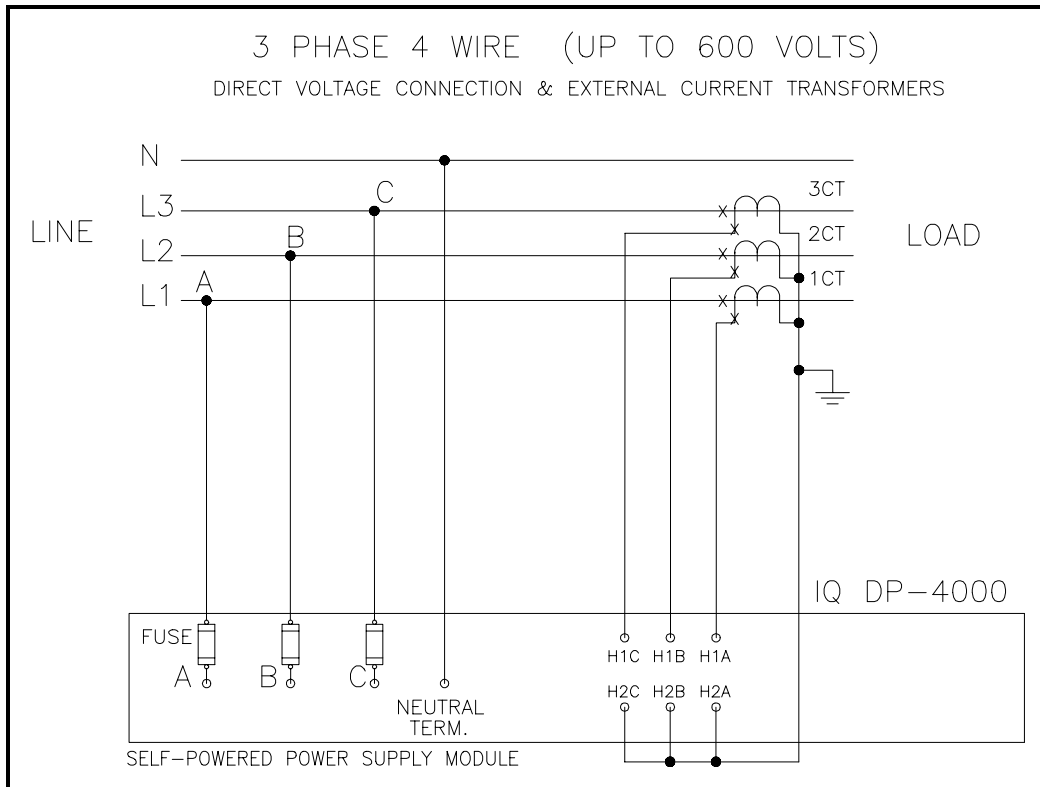

Figure 4.14 3-Phase, 4-Wire (up to 600 volts) Wiring Diagram

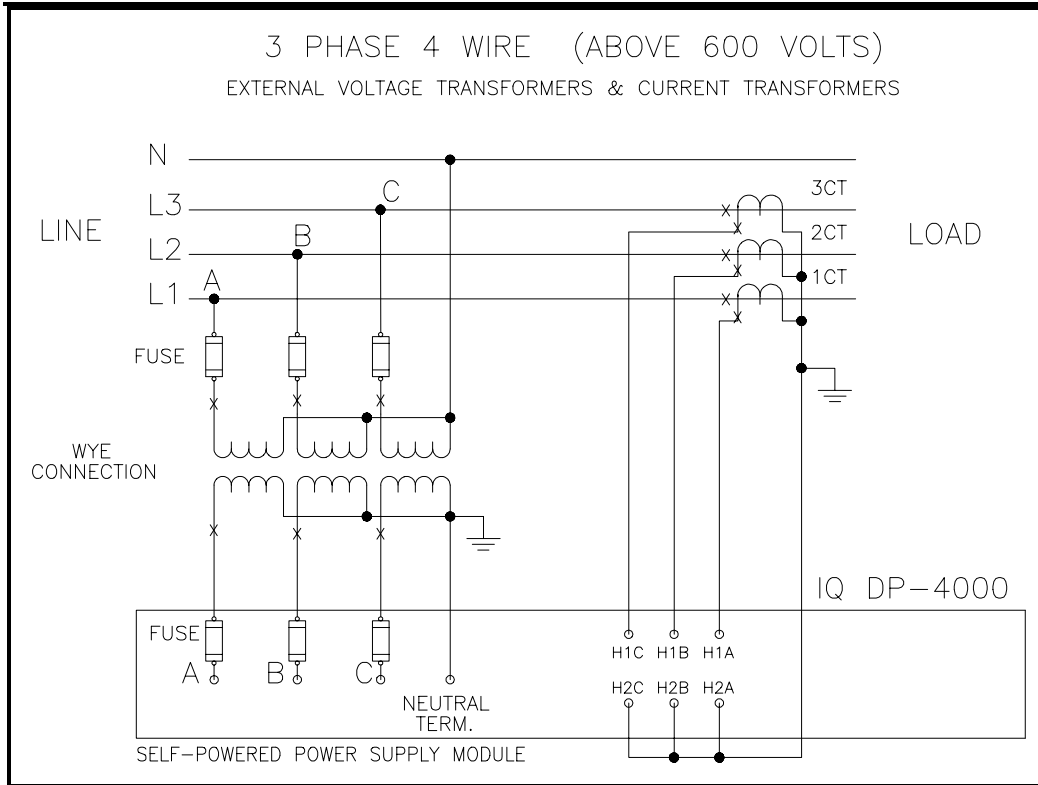

Figure 4.15 3-Phase, 4-Wire (above 600 volts) Wiring Diagram

4.5 INITIAL STARTUP

Follow the initial startup procedure before and when you first apply AC power to the IQ DP-4000. Use this as a checklist to be sure you do not miss any steps.

! WARNING

THE FOLLOWING STARTUP PROCEDURES MUST BE PERFORMED ONLY BY QUALIFIED PERSONNEL WHO ARE FAMILIAR WITH THE IQ DP-4000 AND ITS ASSOCIATED ELECTRICAL AND/OR MECHANICAL EQUIPMENT. FAILURE TO OBSERVE THIS CAUTION CAN RESULT IN SERIOUS INJURY OR EVEN DEATH.

4.5.1 During Initial Power Application

To apply AC power to the IQ DP-4000 for the first time:

1. Verify that the AC power is off.
2. Verify that the line-to-line voltages fall within the correct range, as noted on the wiring plan drawing.
3. Check that all wiring is correct according to the wiring plan drawings.
4. When possible, lockout any foreign power sources and disable the IQ DP-4000 until all other machines or processes are started and thoroughly checked.
5. Restore AC power and verify the operator panel functions, after an initial delay, as follows:
 - The IA Amps LED lights.
 - The Display Window shows the actual line phase A amperes.
6. Set all Setpoint Switches according to the Master Setpoint Record Sheet (Appendix B).

5.1 INTRODUCTION

This section identifies all of the programmable functions of the IQ DP-4000. You program the IQ DP-4000 by specifying setpoint values for functions you want monitored. Set the Select Switch to 0 when you are finished programming the DP-4000.

You use the Select and Setpoint switches to program setpoint values specific to your needs. Table 5.A, Setpoint Master Record Sheet, lists all of the possible

functions that may be set. The left column lists the 15 Select Switches and the top row lists the Setpoint Switches. Appendix B contains a blank Master Setpoint Record Sheet for you to use to record your setpoint values. Use the details in this section to define your setpoint values and record the values in the blank Setpoint Master Record Sheet.

In this section, the available functions are broken into three categories -- general system (Table 5.B), alarm

Select Switch	Setpoint Switches							
	No. 1	No. 2	No. 3	No. 4	No. 5	No. 6	No. 7	No. 8
SW0	Test Position—When you are not programming the unit, turn the setpoint switch to 0.							
SW1	System Configuration	Frequency	Nominal AC Line Voltage				Voltage Transformer Ratio	Current Transformer Primary
SW2	Voltage Transformer Ratio							
SW3	Current Transformer Primary							
SW4	Phase Sequence	Power Demand Fixed/Sliding	Power Demand Time Interval			Current Demand Time Interval		
SW5	Reset Energy	Energy Resolution	Not Used			Var/Power Factor Sign	Discrete Input	Sync Pulse
SW6	Alarm 1 Relay Mode	Alarm 1 Latch/Unlatch	Alarm 1 Overvoltage	Alarm 1 Undervoltage	Alarm 1 Voltage Phase Loss	Alarm 1 Voltage Phase Unbalance	Alarm 1 Voltage Phase Reversal	Alarm 1 Current Phase Loss
SW7	Alarm 2 Relay Mode	Alarm 2 Latch/Unlatch	Alarm 2 Overvoltage	Alarm 2 Undervoltage	Alarm 2 Voltage Phase Loss	Alarm 2 Voltage Phase Unbalance	Alarm 2 Voltage Phase Reversal	Alarm 2 Current Phase Loss
SW8	Alarm 1 Disable/Enable	Alarm 1 Trip Delay			Alarm 1 Reset Delay			Alarm 1 Overvoltage Detection
SW9	Alarm 1 Overvoltage Detection		Alarm 1 Undervoltage Detection			Alarm 1 Voltage Phase Unbalance Detection		
SWA	Alarm 2 Disable/Enable	Alarm 2 Trip Delay			Alarm 2 Reset Delay			Alarm 2 Overvoltage Detection
SWB	Alarm 2 Overvoltage Detection		Alarm 2 Undervoltage Detection			Alarm 2 Voltage Phase Unbalance Detection		
SWC	Alarm 1 Reset Threshold			Alarm 2 Reset Threshold			IMPACC Prgmble	DP-4000 / DP - 2 Mode
SWD	Pulse Initiator Load Shed	Pulse Initiator Parameter			Load Shed /Restore Load Range Settings			
SWE	Load Shed /Restore Load Range							
SWF	Load Shed Parameter				Pulse Initiator Rate			

Table 5.A Setpoint Master Sheet

(Table 5.C) and optional I/O (Table 5.D). In each table, the functions are listed in alphabetical order. The second column of the table identifies the corresponding section that describes valid setpoint values.

General System Functions	Section
System Configuration 3/4 Wire	5.3
Frequency Selection - 50/60 Hz	5.4
Nominal AC Line Voltage setting	5.5
Voltage Transformer Ratio	5.6
Current Transformer Primary	5.7
Phase Sequence - ABC/CBA	5.8
Demand Parameters	
Power Demand, Fixed/Sliding	5.9.1
Power Demand Time Interval	5.9.2
Current Demand Time Interval	5.9.3
Energy Setpoints	
Reset Energy - Enable/Disable	5.10.1
Energy Resolution	5.10.2
Var/Power Factor sign convention (+ or -)	5.11
INCOM Programmable	5.13
DP-4000/DP-2 Mode	5.14

Table 5.B General System Functions

Alarm Functions	Section
Relay Mode 1/Mode 2	5.12.1
Latched/Unlatched Alarm	5.12.2
Activate on Overvoltage	5.12.3
Activate on Undervoltage	5.12.4
Activate on Voltage Phase Loss	5.12.5
Activate on Voltage Phase Unbalance	5.12.6
Activate on Voltage Phase Reversal	5.12.7
Activate on Current Phase Loss	5.12.8
Enable/Disable Alarm	5.12.9
Alarm Delay	5.12.10
Alarm Reset Delay	5.12.11
Overvoltage Detection Level	5.12.12
Undervoltage Detection Level	5.12.13
Voltage Phase Unbalance Detection	5.12.14
Alarm Reset Threshold	5.12.15

Table 5.C Alarm Functions

Optional I/O Functions	Section
Discrete Input Setup	5.15.1
Sync Pulse Setpoints	5.15.2
Pulse Initiator/Load Shed	
Pulse Initiator Settings, Parameter	5.15.3.1
Load Shed Range	5.15.3.2
Load Shed Parameter	5.15.3.3
Pulse Initiator Settings, Rate Selection	5.15.3.4

Table 5.D Optional I/O Functions

5.2 SETTING SETPOINT SWITCHES

To program the IQ DP-4000, you must determine which setpoints you want and then **record and verify all the setpoints before starting any entry**. Appendix B contains both a blank Setpoint Master Record Sheet for recording your setpoint values and, for each function, a table displaying the required Select Switch and Setpoint Switches. *A software utility for setpoint configuration has been developed to aid in programming the IQ DP-4000 and is available from the Cutler-Hammer web site at www.cutlerhammer.eaton.com*

WARNING

BE CAREFUL WHEN REPROGRAMMING THE IQ DP-4000. WHEN YOU CHANGE THE VALUES FOR ONE SETPOINT, BE SURE THAT THE SETPOINT SWITCHES FOR THAT SELECT SWITCH ARE SET TO THE PROPER SETTINGS. WHEN YOU PRESS THE SAVE BUTTON, ALL OF THE SETTINGS FOR THAT SWITCH CHANGE TO THE NEW SETTINGS.

The Setpoint Switches (DIP Switches) are located on a strip at the rear right portion of the chassis just below the Setpoint Display LED bank. Directly below them is the Select Switch and the Save button.

It is essential that all of the desired Setpoint Switch settings for each Select Switch are recorded in the Master Setpoint Record Sheet before programming!

To program the Setpoint Switches:

1. Use the **Master Setpoint Record Sheet** as a guide for the settings.
2. Turn Select Switch to the desired position SW(A-F).
3. Set the Setpoint Switches based on the information in the **Master Setpoint Record Sheet** by sliding the Setpoint Switch to the left to turn the switch off, or to the right to turn it on.

4. Press the Save button briefly to see if the LED's light properly. The corresponding LED will light if the switch is turned on.
5. When the Setpoint Switches for that Select Switch are all in the proper location, press and hold the Save button until the tenth LED lights. The settings are now stored permanently in the device's non-volatile memory.
6. Repeat steps 1 to 5 for each Select Switch.
7. When you are done, set the Select Switch to the 0 position.

5.2.1 Setpoint Switch Programming Example

As an example, let us program the device to accept 100:5 current transformers (CT's). To do this:

1. Turn to Appendix A of this manual and look for the size of CT's that are being used (100:5).

■ = OFF □ = ON ▒ = Not Applicable

Select SW Setpoint Switch Number

Position	1	2	3	4	5	6	7	8
1	▒	▒	▒	▒	▒	▒	▒	▒
3	□	□	■	■	□	■	■	■

Table 5.E Setpoint Switch Settings

2. Turn the Select Switch to position 1. As stated in Appendix A, set the Setpoint Switches as shown in Table 5.E (gray indicates reserved for other setpoints, black indicates OFF and white indicates ON).
3. Push the eighth Setpoint Switch to the left (off). When you press the Save button in step 9, you will lose any previous settings made for SW1 1-7.
4. Briefly press the Save button to confirm the settings. The 8th LED will not light indicating the off position.
5. Press and hold the Save button until the tenth LED lights. The setting for Select Switch 1 is now permanently stored in the device's long-term memory.
6. Turn the Select Switch to position 3.
7. Push the first, second and fifth Setpoint Switches to the right (on). Push the third, fourth, sixth, seventh, and eighth to the left (off).
8. Briefly press the Save button to confirm the settings. The first, second, and fifth LEDs light indicating they are in the on position.
9. Press and hold the Save button until the tenth LED lights. The setting for Select Switch 3 is now

permanently stored in the device's long-term memory.

10. Place the Select Switch to the 0 position.

5.3 SYSTEM CONFIGURATION SETPOINT

The IQ DP-4000 monitors either a 3-conductor or 4-conductor AC line. For example, in a 4-wire system, a transformer's secondary winding is wired in a wye configuration, with the XO neutral terminal ground as the fourth wire. In this case, the XO fourth wire connects to the screw terminal on the power supply. Refer to figures 4.9 and 4.15.

Set Switch **SW1 No. 1** to correspond to the chosen wiring configuration. Set this switch to the:

- OFF position for a 3-wire wiring configuration
- ON position for a 4-wire wiring configuration

When you choose the OFF position for the 3-wire configuration, the front panel will not display the 3 line-to-neutral AC line measurements. The measurements not displayed are:

- V_{A-N} Volts
- V_{B-N} Volts
- V_{C-N} Volts

5.4 FREQUENCY SELECTION SETPOINT

The IQ DP-4000 accepts a nominal line frequency of either 50 or 60 Hz. Place switch **SW1 No. 2** in the:

- OFF position for a 50 Hz system
- ON position for a 60 Hz system

5.5 NOMINAL AC LINE VOLTAGE SETPOINT

The IQ DP-4000 measures AC line voltage in one of two ways:

- Line-to-line (3 Phase 3 Wire)
- Line-to-neutral (3 Phase 4 Wire)

Based on the wiring configuration for the system, you must set switches to indicate the nominal AC line voltage applied to the AC line terminals. Line-to-neutral voltages will not be displayed if the IQ DP-4000 is configured as a 3-wire system.

Note: When external voltage transformers are used, the nominal AC line voltage setting indicates the voltage present on the secondary terminals of the PTs. Also, L-N voltages will not be displayed if the unit is configured as a three-wire.

Switch **SW1 Nos. 3, 4, 5, and 6** specify the nominal AC line voltage. Set the switches according to Table 5.F. Follow the table's line-to-line column when the wiring configuration of the AC line is 3-wire. Use the line-to-neutral column when the AC line configuration is 4-wire.

■ = OFF □ = ON

Voltages (Nominal)		SW1 Switch Settings			
Line-to-Line	Line-to-Neutral	No. 3	No. 4	No. 5	No. 6
110	64	■	■	■	■
120	69	□	■	■	■
208	120	■	□	■	■
220	127	■	■	■	■
240	138	■	■	□	■
380	219	■	■	■	■
416	240	■	■	■	■
460	266	■	■	■	■
480	277	■	■	■	■
575	332	■	■	■	■
600	336	■	■	■	■
600	336	Any other selection			

Table 5.F AC Line Voltage

5.6 VOLTAGE TRANSFORMER RATIO SETPOINT

Some systems may include optional, user-provided potential voltage transformers (this is required above 600V). You must take these ratios into account by using switch **SW1 No. 7**, and the eight switch settings for **SW2 Nos. 1 to 8**. See Appendix A for a listing of the available PT ratios, and their corresponding settings.

5.7 CURRENT TRANSFORMER PRIMARY SETPOINT

The primary winding of the user-provided external current transformers can vary from 5 amps to 12,800 amps; the secondary winding is assumed to be 5 amps. Switch **SW1 No. 8**, and the eight switch settings **SW3 Nos. 1 to 8**, must correspond to the external current transformer's primary rating. See Appendix A for a listing of the available CT primary ratings, and their corresponding settings.

5.8 PHASE SEQUENCE SETPOINT

The IQ DP-4000 can be programmed to correspond to either a nominal ABC or CBA sequence, by a single switch **SW4 No. 1**. A power system with an ABC sequence has phase A leading phase B by 120 degrees, and phase B leading phase C by 120 degrees.

A system with a CBA sequence has phase C leading phase B by 120 degrees, and phase B leading phase A by 120 degrees.

Set switch **SW4 No. 1** in the:

- OFF position for an ABC sequence
- ON position for a CBA sequence

5.9 DEMAND SETPOINTS

If you set up the IQ DP-4000 to use an internal sync pulse (see Section 5.15.2), you must determine the type of demand, and time interval for the demand window. The present demand and peak demand are computed for the following parameters:

- Current Related Parameters. For the current related parameters, the demand calculation is always based on a fixed window. Section 5.9.3 describes programming the current demand times. The current related parameters are:
 - I_A Amps
 - I_B Amps
 - I_C Amps
- Power Related Parameters. For the power related parameters, the demand can be based on either a fixed or sliding window. See Section 5.9.1 for selecting a fixed or sliding demand window and Section 5.9.2 for programming the power related demand times. The power related parameters are:
 - Watts
 - Vars
 - VA

5.9.1 Power Demand, Fixed/Sliding

The IQ DP-4000 is programmed for the power related demand to correspond to either a fixed or sliding window.

- **Fixed Power Demand.** With a fixed demand window, the demand calculation is based on, and updated at, the user-selected time interval. For example, if you select a 15-minute demand window, a new demand will compute every 15 minutes, based on the energy used during the last 15 minutes.
- **Sliding Power Demand.** For a sliding window, the demand calculation is based on the user-selected interval time, and is updated every minute. For example, if you select a 15-minute demand window, the calculated demand is based upon the previous 15 minutes, but is updated every minute.

Set the power related demand by using **SW4 No. 2**.

Place the switch in the:

- OFF position for the sliding power demand window
- ON position for the fixed power demand window

5.9.2 Power Demand Time Interval

Switch **SW4 Nos. 3, 4, and 5** determine the time interval, in minutes, that the consumption sampling for the power related demand calculations are based. Table 5.G shows the settings for selecting the power demand interval.

■ = OFF □ = ON ■ = Not Applicable

Time Interval (minutes)	SW4 Settings		
	No. 3	No. 4	No. 5
5	■	■	■
10	□	■	■
15	■	□	■
20	□	□	■
25	■	■	□
30	□	■	□
45	■	□	□
60	□	□	□

Table 5.G Power Demand Intervals for Watts, Vars and VA

5.9.3 Current Demand Time Interval

Switch **SW4 Nos. 6, 7, and 8** determine the time interval, in minutes, that the consumption sampling for the current related demand calculations are based. Table 5.H shows the settings for selecting the current demand time intervals.

■ = OFF □ = ON

Time Interval (minutes)	SW4 Settings		
	No. 6	No. 7	No. 8
5	■	■	■
10	□	■	■
15	■	□	■
20	□	□	■
25	■	■	□
30	□	■	□
45	■	□	□
60	□	□	□

Table 5.H Demand Sampling Interval for I_A, I_B, and I_C

5.10 ENERGY SETPOINTS

5.10.1 Reset Energy from Faceplate Setpoint

This setpoint enables or prevents you from resetting the energy values (Watt-hours, Var-hours, and VA-hours) from the faceplate. Set Switch **SW5 No. 1** in the:

- OFF position to prevent resetting an energy value from the faceplate
- ON position to enable resetting at the faceplate. To reset an energy value from the faceplate, you select the parameter (Metered Watt-hours, Var-hours, or VA-hours), and then hold down the Reset button until the value is 0.

5.10.2 Energy Resolution

The IQ DP-4000 can be programmed to display energy readings in KILO or MEGA energy units. A single switch **SW5 No. 2** sets the energy resolution. The energy value rolls-over to zeros when it exceeds 999999.

Set switch **SW5 No. 2** in the:

- OFF position for KILO energy units
- ON position for MEGA energy units

5.11 VAR/POWER FACTOR SIGN CONVENTION SETPOINT

This setpoint selects the sign convention (+ or -) for the Var and the Power Factor values. The sign conventions can be either negative or positive.

- A negative sign convention corresponds to:
 - Inductive Load = Negative Var and Power Factor Values (Lagging Power Factor)
 - Capacitive Load = Positive Var and Power Factor Value (Leading Power Factor)
- A positive sign convention corresponds to:
 - Inductive Load = Positive Var and Power Factor Values (Lagging Power Factor)
 - Capacitive Load = Negative Var and Power Factor Values (Leading Power Factor)

Power engineers typically use the positive sign convention as the standard convention; the negative sign convention is mathematically correct.

Figures 3.2 and 3.3 illustrate the two Var and Power Factor sign conventions.

Set Switch **SW5 No. 6** in the:

- OFF position for a negative sign convention
- ON position for a positive sign convention

5.12 ALARM FUNCTIONS - GENERAL

The DP-4000 has two independent alarms, Alarm 1 and Alarm 2. The faceplate of the IQ DP-4000 has two LEDs to indicate the state of each of these alarms. A “steady-on” LED indicates an active alarm. If the optional I/O module is installed, the relays will change state when the corresponding alarm LED is illuminated. Both of the alarms have the features outlined in Table 5.C.

5.12.1 Relay Modes Alarm Setpoint

This setpoint is used only if the IQ DP-4000 is equipped with the optional I/O module. Select one of two different alarm relay reaction modes in response to a number of operating conditions. These are:

- Mode 1. Alarm relay is de-energized normally and energizes during an alarm condition
- Mode 2. Alarm relay is energized normally and de-energizes during a loss of AC control power

You must select one of these two modes for each alarm. Your choice depends on the desired effect of an AC power loss on an application, as described in

Paragraphs 5.12.13.1 and 5.12.13.2. See Table 5.I for setting the alarm modes for the relays.

5.12.1.1 Mode 1

When alarm mode 1 is selected, the alarm relay will energize only on an alarm condition. The alarm relay is in the de-energized state:

- When the IQ DP-4000 is not powered
- During normal operation, with no alarms active (the corresponding Alarm LED is not “steady-on” when viewing from the faceplate)

During **normal operation**, when the alarm relay is in the de-energized state, the **normally-closed contacts are closed**.

When an alarm occurs, the normally-closed contacts open, and the normally open contacts close. The advantage of this mode of operation is that if a failure of the IQ DP-4000 occurs (a loss of power), the relay will remain in the same state, as if no alarms are active.

Note: It is your responsibility to choose the NO/NC pair of Alarm Relay contact to perform the desired operation.

5.12.1.2 Mode 2

When alarm mode 2 is selected, the alarm relay will energize after initial power up and de-energize on a trip condition. The alarm relay is in the energized state. This occurs when:

- After the normal AC power-up sequence
- During normal operation, with no alarms active (the corresponding Alarm LED is not “steady-on” when viewing from the faceplate)

During **normal operation**, when the alarm relay is in the energized state, the **normally-closed contacts are open**.

When an alarm occurs, the normally-closed contacts close, and the normally-open contacts open.

The advantage of this mode of operation is that if a failure of the IQ DP-4000 occurs (a loss of power), the relay will change state, as if an alarm occurs.

Alarm 1	Alarm 2	Position
SW6 No. 1	SW7 No. 1	OFF for Mode 1 ON for Mode 2

Table 5.I Alarm Relay Mode Setting

5.12.2 Latched/Unlatched (Auto-reset) Alarm Setpoint

This setpoint allows the IQ DP-4000 to operate in one of two ways - the latched mode or the unlatched mode.

See Table 5.J for setting this option.

- Latched Mode. In the latched mode, you can only reset an active alarm manually (either from the faceplate, the reset input, or over IMPACC). The alarm **will not** automatically clear once the reset conditions are met. If the alarm condition still exists, you cannot reset the alarm unless you disable it.
- Unlatched Mode (auto-reset). If an alarm occurs, the DP-4000 will automatically reset the alarm when the reset conditions are met, based on the program settings (for example, reset thresholds and reset delays). The DP-4000 will not reset if the alarm condition still exists.

Alarm 1	Alarm 2	Position
SW6 No. 2	SW7 No. 2	OFF for Unlatched
		ON for Latched

Table 5.J Latched/Unlatched Settings

5.12.3 Activate on Overvoltage Alarm Setpoint

This setpoint activates the selected alarm on an overvoltage condition. When enabled, the IQ DP-4000 compares the metered line-to-line voltage of each phase to the overvoltage detection level (see Section 5.12.12), and activates the alarm if the threshold is exceeded for a time greater than the alarm delay on any phase (see Section 5.12.10). See Table 5.K for setting this option.

Alarm 1	Alarm 2	Position
SW6 No. 3	SW7 No. 3	OFF disables Activate on Overvoltage
		ON enables Activate on Overvoltage

Table 5.K Activate on Overvoltage Settings

5.12.4 Activate on Undervoltage Alarm Setpoint

This setpoint activates the selected alarm on an undervoltage condition. If enabled, the IQ DP-4000 compares the metered line-to-line voltage of each phase to the undervoltage detection level (see Section 5.12.13), and activates the alarm if the metered voltage is below the threshold for a time greater than the alarm delay on any phase (see Section 5.12.10). See Table 5.L for setting this option.

Alarm 1	Alarm 2	Position
SW6 No. 4	SW7 No. 4	OFF disables Activate on Undervoltage
		ON enables Activate on Undervoltage

Table 5.L Activate on Undervoltage Settings

5.12.5 Activate on Voltage Phase Loss Alarm Setpoint

This setpoint activates the selected alarm on a voltage phase loss condition. A voltage phase loss occurs when the line-to-line voltage on any phase is less than 50% of the nominal line voltage.

When this alarm is set, the IQ DP-4000 compares the metered voltage to 50% of the selected nominal voltage (see Section 5.5), and activates the alarm if a voltage phase loss exists for a time greater than the alarm delay (see Section 5.12.10). See Table 5.M for setting this option.

Alarm 1	Alarm 2	Position
SW6 No. 5	SW7 No. 5	OFF disables Activate on Voltage Phase Loss
		ON enables Activate on Voltage Phase Loss

Table 5.M Activate on Voltage Phase Loss Settings

5.12.6 Activate on Voltage Phase Unbalance Alarm Setpoint

This setpoint activates the alarm on a voltage phase unbalance condition. The IQ DP-4000 compares the metered voltage to the voltage phase unbalance detection level (see Section 5.12.14), and activates the alarm if the maximum deviation between any two phases of the metered voltage exceeds the threshold for longer than the alarm delay (see Section 5.12.10). Table 5.N shows the settings for this option.

Alarm 1	Alarm 2	Position
SW6 No. 6	SW7 No. 6	OFF disables Activate on Voltage Phase Unbalance
		ON enables Activate on Voltage Phase Unbalance

Table 5.N Activate on Voltage Phase Unbalance Settings

5.12.7 Activate on Voltage Phase Reversal Alarm Setpoint

This setpoint activates the alarm on a voltage phase reversal condition. The IQ DP-4000 compares the

phase rotation of the metered voltages to the selected phase sequence of the system (see Section 5.8), and activates the alarm if the order of the phases does not correspond for longer than the alarm delay (see Section 5.12.10). See Table 5.O for setting this option.

Alarm 1	Alarm 2	Position
SW6 No. 7	SW7 No. 7	OFF disables Activate on Voltage Phase Reversal
		ON enables Activate on Voltage Phase Reversal

Table 5.O Activate on Voltage Phase Reversal Settings

5.12.8 Activate on Current Phase Loss Alarm Setpoint

This setpoint allows the selected alarm to activate on a current phase loss condition. A current phase loss occurs when the current on any one phase is less than 6.25% of the largest current of the other 2 phases. The IQ DP-4000 activates the alarm if a current phase loss exists for longer than the alarm delay (see Section 5.12.10). Table 5.P shows the settings for this option.

Alarm 1	Alarm 2	Position
SW6 No. 8	SW7 No. 8	OFF disables Activate on Current Phase Loss
		ON enables Activate on Current Phase Loss

Table 5.P Activate on Current Phase Loss Settings

5.12.9 Enable/Disable Alarm Setpoint

The alarms disable or enable with a single switch (see Table 5.Q). When you select OFF, the alarm will not activate on any of the six conditions, regardless of the other setpoints. An IMPACC external alarm will, however, activate the alarm.

Alarm 1	Alarm 2	Position
SW8 No. 1	SWA No. 1	OFF to disable alarm
		ON to enable alarm

Table 5.Q Enable/Disable Alarm

5.12.10 Alarm Delay Setpoint

To determine how long a condition exists before an alarm activates, you must set the alarm delay. Both alarms have an independent alarm delay; however, the delay setting is common to all six alarm conditions.

The alarm delay times how long the condition is continuously above any active alarm threshold, and activates the alarm when the preset time is exceeded.

The timer resets when the condition is below the alarm threshold. See Table 5.R for setting the alarm delays.

■ = OFF □ = ON

Alarm 1			Alarm 2			Delay
SW8 No. 2	SW8 No. 3	SW8 No. 4	SWA No. 2	SWA No. 3	SWA No. 4	Time (seconds)
■	■	■	■	■	■	1
■	■	■	■	■	■	2
■	■	■	■	■	■	3
■	■	■	■	■	■	4
■	■	■	■	■	■	5
■	■	■	■	■	■	10
■	■	■	■	■	■	15
■	■	■	■	■	■	20

Table 5.R Alarm Delay Settings

5.12.11 Alarm Reset Delay Setpoint

For the reset delay, the IQ DP-4000 determines how long the condition must be corrected before the corresponding alarm is reset. Both alarms have an independent reset delay; however, the delay setting is common to all six alarm conditions.

The reset delay measures how long the condition is continuously within the reset threshold, and clears the alarm only when the preset delay time is exceeded. The delay timer resets to zero when the condition is no longer within the alarm reset threshold. See Table 5.S to set the alarm reset delays.

■ = OFF □ = ON

Alarm 1			Alarm 2			Delay
SW8 No. 5	SW8 No. 6	SW8 No. 7	SWA No. 5	SWA No. 6	SWA No. 7	Time (seconds)
■	■	■	■	■	■	1
■	■	■	■	■	■	5
■	■	■	■	■	■	10
■	■	■	■	■	■	20
■	■	■	■	■	■	30
■	■	■	■	■	■	60
■	■	■	■	■	■	90
■	■	■	■	■	■	120

Table 5.S Reset Delay Settings

5.12.12 Overvoltage Detection Level Alarm Setpoint

This setpoint activates the alarm on an overvoltage condition (see Section 5.12.3). You must determine the overvoltage detection level. The overvoltage detection level is selected as a larger percentage of the nominal AC line voltage (see Section 5.5).

If the sampled voltage is greater than the overvoltage detection level for longer than the alarm delay (see Section 5.12.10), the enabled alarm activates. See Table 5.T for setting the overvoltage detection level.

■ = OFF □ = ON

Alarm 1			Alarm 2			Detection Level
SW8 No. 8	SW9 No. 1	SW9 No. 2	SWA No. 8	SWB No. 1	SWB No. 2	%
■	■	■	■	■	■	105
■	■	■	■	■	■	110
■	■	■	■	■	■	115
■	■	■	■	■	■	120
■	■	■	■	■	■	125
■	■	■	■	■	■	130
■	■	■	■	■	■	135
■	■	■	■	■	■	140

Table 5.T Overvoltage Detection Level Settings

5.12.13 Undervoltage Detection Level Setpoint

The undervoltage detection level is a lower percentage of the nominal AC line voltage. When the alarm is set to activate on an undervoltage, you must determine the detection level. See Sections 5.5 and 5.12.4.

The alarm activates when the sampled voltage is less than the undervoltage detection level for longer than the alarm delay (see Section 5.12.10).

■ = OFF □ = ON

Alarm 1			Alarm 2			Detection Level
SW9 No. 3	SW9 No.4	SW9 No. 5	SWB No. 3	SWB No. 4	SWB No. 5	%
■	■	■	■	■	■	60
■	■	■	■	■	■	65
■	■	■	■	■	■	70
■	■	■	■	■	■	75
■	■	■	■	■	■	80
■	■	■	■	■	■	85
■	■	■	■	■	■	90
■	■	■	■	■	■	95

Table 5.U Undervoltage Detection Level Settings

5.12.14 Voltage Phase Unbalance Detection Level Alarm Setpoint

If the selected alarm has been set to activate on a voltage phase unbalance (see Section 5.12.6), you must determine the voltage phase unbalance detection level. A voltage phase unbalance is calculated by taking the maximum voltage deviation between any two phases

and comparing that voltage to a percentage of the nominal AC line voltage.

If the sampled voltage deviation is greater than the voltage phase unbalance detection level for longer than the alarm delay (see Section 5.12.10), the alarm activates. See Table 5.V for setting the voltage phase unbalance detection level.

■ = OFF □ = ON

Alarm 1			Alarm 2			Detection Level
SW9 No. 6	SW9 No. 7	SW9 No. 8	SWB No. 6	SWB No. 7	SWB No. 8	%
■	■	■	■	■	■	5
■	■	■	■	■	■	10
■	■	■	■	■	■	15
■	■	■	■	■	■	20
■	■	■	■	■	■	25
■	■	■	■	■	■	30
■	■	■	■	■	■	35
■	■	■	■	■	■	40

Table 5.V Voltage Phase Unbalance Detection Level Settings

5.12.15 Alarm Reset Threshold Setpoint

The IQ DP-4000 has three alarm conditions with programmable thresholds:

- overvoltage
- undervoltage
- voltage phase unbalance

You must set the levels for the IQ DP-4000 alarm to reset. Both alarms have an independent reset threshold; however, the reset threshold is common to all three alarm conditions.

The reset threshold is based on the detection levels set for the alarm conditions, as well as the nominal AC line voltage. The reset thresholds are described for each of the three programmable alarm conditions. See Table 5.W for setting the reset threshold.

■ = OFF □ = ON

Alarm 1			Alarm 2			Reset Level,
SWC No. 1	SWC No. 2	SWC No. 3	SWC No. 4	SWC No. 5	SWC No. 6	%
■	■	■	■	■	■	0
□	■	■	■	■	■	10
■	□	■	■	■	■	20
□	□	■	■	■	■	30
■	■	□	■	■	■	40
□	■	□	■	■	■	50
■	□	□	■	■	■	75
□	□	□	□	□	□	100

Table 5.W Reset Threshold Settings

5.12.15.1 Overvoltage Reset Threshold

To determine the threshold level to reset the overvoltage, find the voltage when an overvoltage alarm will occur. This is the nominal AC line voltage (see Section 5.5) multiplied by the overvoltage detection level (see Section 5.12.12). Figure 5.1 illustrates the overvoltage set and reset levels.

The reset voltage is a percentage of the difference (0 to 100%) between the nominal voltage and the overvoltage detection level, as determined by the reset threshold. You can calculate this by:

$$OVR = OVDL - RST \times (OVDL - NOM)$$

where

OVR = Overvoltage Reset (Volts)

RST = Reset Threshold

OVDL = Overvoltage Detection Level (Volts)

NOM = Nominal AC line Voltage (Volts)

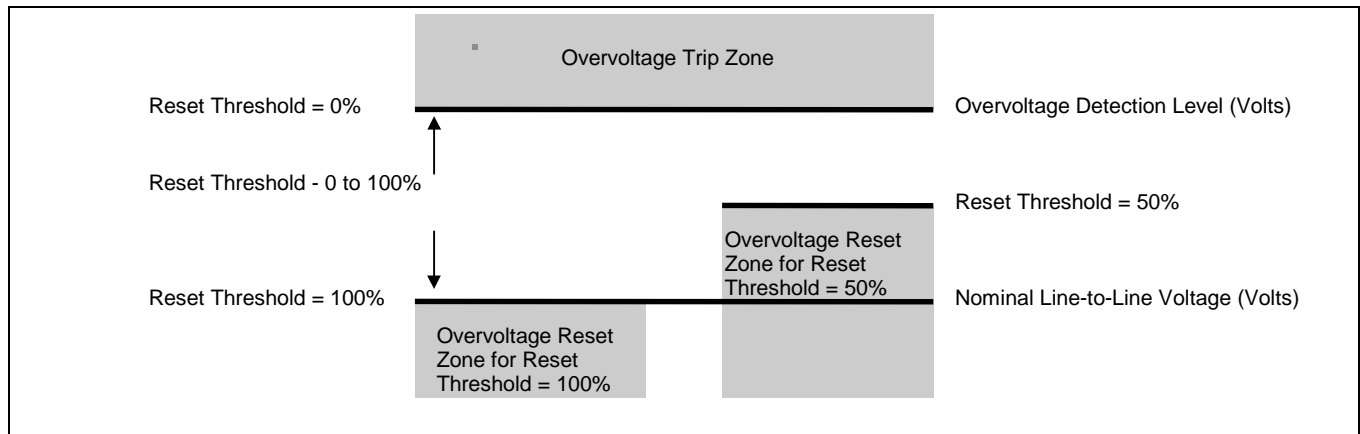

Figure 5.1 Overvoltage Detection and Reset Levels

Example 1

A system has the following settings:

- Nominal AC Line Voltage = 208 V
- Overvoltage Detection Level = 125%
- Reset Threshold = 75%

For this system an overvoltage alarm will occur at:

$$208V \times 125\% = 260V$$

The overvoltage alarm will reset at:

$$\begin{aligned} &260V - 75\% \times (260V - 208V) \\ &= 260V - 75\% \times (52V) \\ &= 260V - 39V = 221V \end{aligned}$$

In this example, the overvoltage alarm will not reset until the system voltage is below 221V.

Example 2

A system has the following settings:

- Nominal AC Line Voltage = 480 V
- Overvoltage Detection Level = 110%

To determine the Reset Threshold setting for the overvoltage alarm to reset below 504 V:

The overvoltage alarm will occur at

$$480V \times 110\% = 528 V$$

$$504V = 528V - RST\% \times (528V - 480V)$$

$$504V = 528V - RST\% \times (48V)$$

$$RST\% \times (48V) = 528V - 504V = 24V$$

$$RST\% = 24V / 48V = 0.50$$

In this case, set the reset threshold to 50%

5.12.15.2 Undervoltage Reset Threshold

To determine where to reset an undervoltage alarm, find the voltage where the undervoltage alarm occurs. This voltage is the nominal AC line voltage (see Section 5.5) multiplied by the undervoltage detection level (see Section 5.12.13).

The reset voltage is a percentage of the difference (0 to 100%) between the nominal Voltage and the undervoltage detection level, as determined by the reset threshold. Compute this by:

$$UVR = UVDL + RST \times (NOM - UVDL)$$

where

UVR = Undervoltage Reset (Volts)

UVDL = Undervoltage Detection Level (Volts)

RST = Reset Threshold

NOM = Nominal AC line Voltage (Volts)

Figure 5.2 illustrates the undervoltage detection and reset levels.

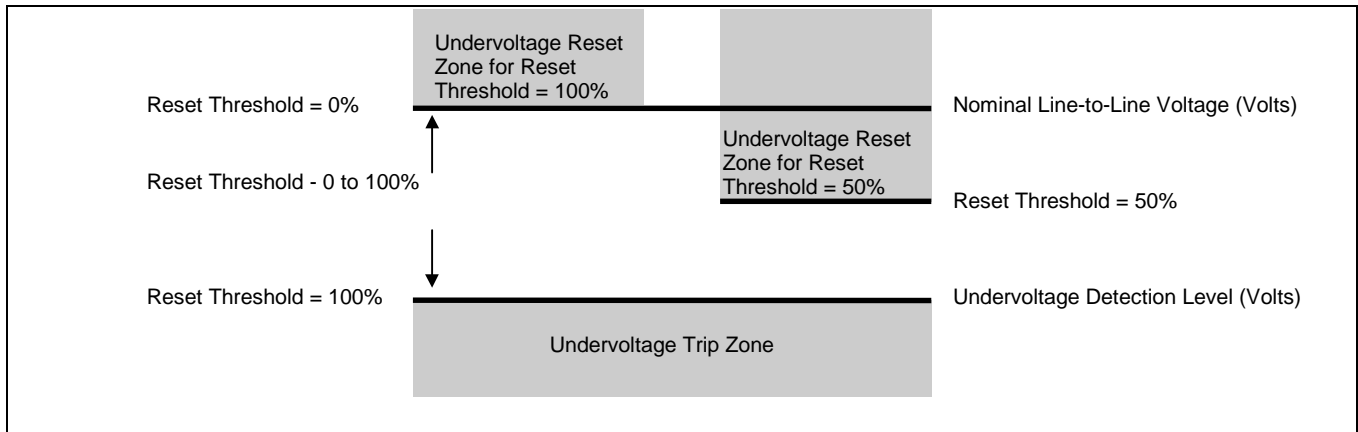

Figure 5.2 Undervoltage Detection and Reset Levels

Example 1

A system has the following settings:

- Nominal AC Line Voltage = 208 V
- Undervoltage Detection Level = 80%
- Reset Threshold = 75%

For this system: An undervoltage alarm will occur at

$$208V \times 80\% = 166V$$

The undervoltage alarm will reset at

$$\begin{aligned} &166V + 75\% \times (208V - 166V) \\ &= 166V + 75\% \times (42V) \\ &= 166V + 32V = 198V \end{aligned}$$

In this example, the undervoltage alarm will not reset until the system voltage is above 198V.

Example 2

A system has the following settings:

- Nominal AC Line Voltage = 480 V
- Undervoltage Detection Level = 75%

Determine the reset threshold setting for the undervoltage alarm to reset above 420 V. The undervoltage alarm occurs at:

$$\begin{aligned} 480V \times 75\% &= 360V \\ 420V &= 360V + RST\% \times (480V - 360V) \end{aligned}$$

$$\begin{aligned} 420V &= 360V + RST\% \times (120V) \\ RST\% \times (120V) &= 420V - 360V = 60V \\ RST\% &= 60V / 120V = 0.50 \end{aligned}$$

In this case, set the reset threshold to 50% .

5.12.15.3 Voltage Phase Unbalance Reset Threshold

A voltage phase unbalance occurs when the maximum voltage deviation between two phases is greater than a percentage of the nominal AC line voltage. To find the voltage level, calculate where a voltage phase unbalance alarm will occur. To do this, multiply the nominal AC line voltage (see Section 5.5) by the voltage phase unbalance detection level (see Section 5.12.14).

The reset voltage is a percentage of the difference (100 to 0%) between zero volts (all of the phases being equal in voltage) and the voltage phase unbalance detection level, as determined by the reset threshold. Compute this by:

$$VPU = MVD - MVD \times RST$$

where

- VPU = Voltage Phase Unbalance Reset (Volts)
- MVD = Maximum Voltage Deviation where a Phase Unbalance Alarm occurs (Volts)
- RST = Reset Threshold

Figure 5.3 illustrates the voltage phase unbalance detection and reset levels.

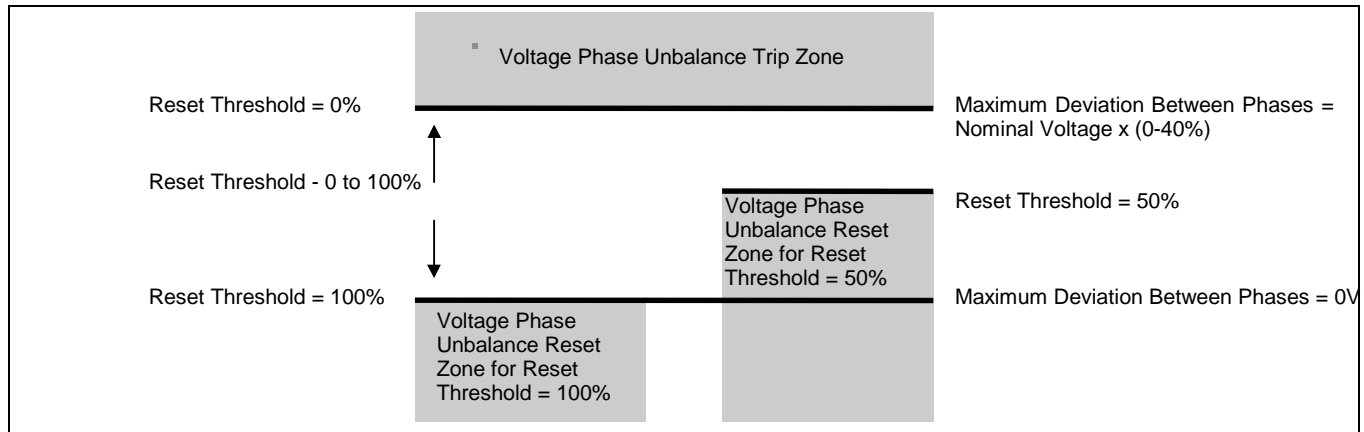

Figure 5.3 Voltage Phase Unbalance Detection and Reset Levels

Example 1

A system has the following settings:

Nominal AC Line Voltage = 208 V

Voltage Phase Unbalance Detection Level = 15%

Reset Threshold = 75%

For this system a voltage phase unbalance alarm occurs when any 2 phases have a voltage difference greater than:

$$208V \times 15\% = 31V$$

The voltage phase unbalance alarm resets when all 3 phases are within:

$$31V - (31V \times 75\%) = 8V \text{ of each other}$$

Example 2

A system has the following settings:

Nominal AC Line Voltage = 480 V

Voltage Phase Unbalance Detection Level = 25%

Determine the reset threshold setting for the voltage phase unbalance alarm to reset when all 3 phases of voltage are within 84V of each other: The voltage phase unbalance alarm will occur when any 2 phases have a voltage difference greater than:

$$480V \times 25\% = 120V$$

$$84V = 120V - 120V \times RST$$

$$120V \times RST = 120V - 84V$$

$$120V \times RST = 36V$$

$$RST = 36V / 120V = 0.3$$

In this case, set the reset threshold to 30% .

5.13 IMPACC PROGRAMMABLE SETPOINT

You can allow programming of the IQ DP-4000 using IMPACC with this setpoint. You must enable this setpoint in order to download information to the IQ DP-4000 from Cutler Hammer's Series III software. Set Switch **SWC No. 7** in the:

- OFF position to disable programming of the DP-4000 via IMPACC
- ON position to enable programming of the DP-4000 via IMPACC

If disabled, the DP-4000 will continue to communicate over IMPACC, although you cannot change the setpoints remotely.

5.14 DP-4000 / DP-2 MODE SETPOINT

This setpoint allows the DP-4000 to communicate over Cutler-Hammer's Integrated Monitoring, Protection and Control Communications System (IMPACC) either as a DP-4000 or as a Data Plus II (DP2). This setpoint affects communications only. It does not affect the operation of the unit. This allows DP-4000 compatibility with older, existing systems. Set Switch **SWC No. 8** in the:

- OFF position to communicate as a Data Plus II
- ON position to communicate as a DP-4000

5.15 OPTIONAL I/O SETPOINTS

These setpoints are relevant only if the IQ DP-4000 is equipped with the optional I/O module.

5.15.1 Discrete Input Setup Setpoint

Note: This setpoint is relevant only if the IQ DP-4000 is equipped with the optional I/O module.

The IQ DP-4000 discrete input is configured to either a sync pulse input or a reset input. Set Switch **SW5 No. 7** in the:

- OFF position to function as a sync pulse
- ON position to have the discrete input function as a reset input

If the discrete input is set up as a sync pulse input, a dry contact closure across the terminal blocks of the discrete input will cause the start of a new demand window. The sync window time can be variable or fixed, determined by setting the sync pulse setpoint (see 5.15.3).

If the discrete input is set up as a reset input, a dry contact closure across the terminal blocks of the discrete input will attempt to reset an active alarm. (This is identical to using the Reset pushbutton when resetting an alarm.)

5.15.2 Sync Pulse Setpoint

Note: This setpoint is relevant only if the IQ DP-4000 is equipped with the optional I/O module.

The IQ DP-4000 is designed to calculate the demand either by an internal synchronizing timer or by an external signal.

Set Switch **SW5 No. 8** in the:

- OFF position to calculate demand based on an external signal (see Section 5.15.1 - Discrete Input Setup)
- ON position to calculate demand based on a pre-programmed time (see Section 5.9 - Demand Parameters)

5.15.3 Pulse Initiator/Load Shed Setpoint

The IQ DP-4000 has a relay which can be programmed based on the amount of power and energy measured. The pulse initiator function tracks the amount of energy measured and the load shed function changes the state of a relay when a predetermined power threshold is exceeded.

Set Switch **SWD No. 1** in the:

- OFF position to use relay for the pulse initiator function (see Section 5.15.3.1)
- ON position to use relay for the load shed function (see Section 5.15.3.4)

5.15.3.1 Pulse Initiator Settings, Parameter Selection

The pulse initiator changes the state of the pulse initiator relay at a rate proportional to the amount of energy the IQ DP-4000 measures, based on a user-selected energy parameter and pulse rate. Select one of the following parameters to track with the pulse initiator:

- Watt-hours (positive or negative)
- Var-hours (positive or negative)
- VA-hours

See Table 5.X for selecting the energy parameter.

■ = OFF □ = ON

Energy Parameter	SWD Settings		
	No. 2	No. 3	No. 4
Positive Watt-hours			
Negative Watt-hours			
Positive Var-hours			
Negative Var-hours			
VA-hours			
Invalid	Any Other Selection		

Table 5.X Pulse Initiator Parameter Selection Settings

5.15.3.2 Load Shed Settings, Range Selection

Two ranges are associated with the load shed feature: a Load Shed range and a Restore Load range. Both ranges are set as a percentage of the nominal values for the system. When the Load Shed range is exceeded, the relay activates. This relay remains active until the value of the selected parameter drops below the Restore Load range.

The nominal system voltage is explained in Section 5.5.

The nominal system current is the value selected for the CT primary (Section 5.7).

The nominal system power is the product of the nominal system voltage and nominal system current. See Table 5.Y for setting the load shed and restore load ranges.

■ = OFF □ = ON

Ranges	Switch Settings						
	Select Switch	SWE	SWE	SWE	SWE	SWD	SWD
Load Shed, % of nominal	Setpoint Switch	No. 1	No. 2	No. 3	No. 4	No. 5	No. 6
Restore Load, % of nominal	Select Switch	SWE	SWE	SWE	SWE	SWD	SWD
	Setpoint Switch	No. 5	No. 6	No. 7	No. 8	No. 7	No. 8
10		■	■	■	■	■	■
12		■	■	■	■	■	■
14		■	■	■	■	■	■
16		■	■	■	■	■	■
18		■	■	■	■	■	■
20		■	■	■	■	■	■
22		■	■	■	■	■	■
24		■	■	■	■	■	■
26		■	■	■	■	■	■
28		■	■	■	■	■	■
30		■	■	■	■	■	■
32		■	■	■	■	■	■
34		■	■	■	■	■	■
36		■	■	■	■	■	■
38		■	■	■	■	■	■
40		■	■	■	■	■	■
42		■	■	■	■	■	■
44		■	■	■	■	■	■
46		■	■	■	■	■	■
48		■	■	■	■	■	■
50		■	■	■	■	■	■
52		■	■	■	■	■	■
54		■	■	■	■	■	■
56		■	■	■	■	■	■
58		■	■	■	■	■	■
60		■	■	■	■	■	■
62		■	■	■	■	■	■
64		■	■	■	■	■	■
66		■	■	■	■	■	■
68		■	■	■	■	■	■
70		■	■	■	■	■	■
72		■	■	■	■	■	■
74		■	■	■	■	■	■
76		■	■	■	■	■	■
78		■	■	■	■	■	■
80		■	■	■	■	■	■
82		■	■	■	■	■	■

Table 5.Y Load Shed and Restore Load Settings (continued on next page)

■ = OFF □ = ON

Ranges	Switch Settings						
	Select Switch	SWE	SWE	SWE	SWE	SWD	SWD
Load Shed, % of nominal	Setpoint Switch	No. 1	No. 2	No. 3	No. 4	No. 5	No. 6
	Select Switch	SWE	SWE	SWE	SWE	SWD	SWD
Restore Load, % of nominal	Setpoint Switch	No. 5	No. 6	No. 7	No. 8	No. 7	No. 8
	Select Switch	SWE	SWE	SWE	SWE	SWD	SWD
84		■	■	□	■	■	□
86		■	□	□	■	■	□
88		□	□	□	■	■	□
90		■	■	■	□	■	■
92		□	■	■	□	■	■
94		■	□	■	□	■	■
96		□	□	■	□	■	■
98		■	■	□	□	■	■
100		□	■	□	□	■	■
102		■	□	□	□	■	■
104		□	□	□	□	■	■
106		■	■	■	■	□	□
108		□	■	■	■	□	□
110		■	□	■	■	□	□
112		□	□	■	■	□	□
114		■	■	□	■	□	□
116		□	■	□	■	□	□
118		■	□	□	■	□	□
120		□	□	□	■	□	□
122		■	■	■	□	□	□
124		□	■	■	□	□	□
126		■	□	■	□	□	□
128		□	□	■	□	□	□
130		■	■	□	□	□	□
132		□	■	□	□	□	□
134		■	□	□	□	□	□
136		□	□	□	□	□	□

Table 5.Y Load Shed and Restore Load Settings

5.15.3.3 Load Shed Settings, Parameter Selection

The load shed feature activates the pulse initiator relay when a user-selected parameter exceeds a preprogrammed range (see Section 5.15.3.2). Select one of the following parameters to monitor:

- Watts - Metered or Demand
- VA - Metered or Demand
- Metered Currents - I_A, I_B, I_C, or average
- Demand Currents- I_A, I_B, I_C, or average

See Table 5.Z for selecting the parameter to monitor with the load shed feature.

■ = OFF □ = ON

Parameter Selection	SWF Settings			
	No. 1	No. 2	No. 3	No. 4
Watts, metered	■	■	■	■
Watts, demand	■	■	■	■
VA, metered	■	■	■	■
VA, demand	■	■	■	■
I _A Current, metered	■	■	■	■
I _B Current, metered	■	■	■	■
I _C Current, metered	■	■	■	■
Ave. Current, metered	■	■	■	■
I _A Current, demand	■	■	■	■
I _B Current, demand	■	■	■	■
I _C Current, demand	■	■	■	■
Ave. Current, demand	■	■	■	■
Invalid	Any other selection			

Table 5.Z Load Shed Parameter Selection Settings

5.15.3.4 Pulse Initiator Settings, Rate Selection

For this function, select the rate at which the relay changes state as a value of energy to track with the pulse initiator. For example, if you choose Watt-hours as the parameter to track with the pulse initiator, the IQ DP-4000 will change the state of the relay at every specified interval of Watt-hours. If 50 Watt-hours per Pulse is selected, the relay changes state every time 50 Watt-hours accumulate.

The energy per pulse corresponds to the energy (in units), at the **secondary** winding of the PTs and CTs. Therefore, you must consider the user-selected CT and PT ratios when selecting the Energy per Pulse value. See Table 5.AA for selecting the rate at which the pulse initiator relay changes state.

Example: A system has the following configuration:

CT = 1400:5 PT = 240:120

The IQ DP-4000 is monitoring a constant power of 16,800 Watts.

Watt-hours is selected as the parameter for the pulse initiator setting.

The CT ratio is $1400 / 5 = 280$

The PT ratio is $240 / 120 = 2$

The power at the secondary of the CTs and PTs is:

$$16,800 \text{ Watts} / 280 \times 2 =$$

$$16,800 \text{ Watts} / 560 =$$

$$30 \text{ Watts (or 30 Watt-hours in 1 hour)}$$

- If the energy per pulse is set to 1, each pulse will equal 560 Watt-hours.

$$1400 \times 240 \times 1 = 560 \text{ Watt-hours per pulse.}$$

$$5 \quad 120$$

- If the energy per pulse is set to 7, each pulse will equal 3,920 Watt-hours.

$$1400 \times 240 \times 7 = 3920 \text{ Watt-hours per pulse.}$$

$$5 \quad 120$$

■ = OFF □ = ON

Energy per Pulse	SWF Settings			
	No. 5	No. 6	No. 7	No. 8
1	■	■	■	■
2	■	■	■	■
3	■	■	■	■
4	■	■	■	■
5	■	■	■	■
6	■	■	■	■
7	■	■	■	■
8	■	■	■	■
9	■	■	■	■
10	■	■	■	■
20	■	■	■	■
40	■	■	■	■
50	■	■	■	■
60	■	■	■	■
80	■	■	■	■
100	■	■	■	■

Table 5.AA Pulse Initiator Rate Selection Settings

6.1 LEVEL OF REPAIR

This manual is written assuming you will perform only unit-level troubleshooting. If you trace the cause of a malfunction to the IQ DP-4000, replace the unit with a spare and return the malfunctioning unit to Cutler-Hammer for factory repairs.

6.2 MAINTENANCE AND CARE

The IQ DP-4000 is designed to be a self-contained and maintenance-free unit. The printed circuit boards are calibrated and conformally coated at the factory. They are intended for service by factory trained personnel only.

Operate the IQ DP-4000 in an environment within the temperature range of -25°C to +70°C. The environment should also be free of excess humidity.

If you have spare units, store them in the original packing material and container.

6.3 TROUBLESHOOTING

This section divides troubleshooting into two parts:

- Troubleshooting during initial startup (refer to Table 6.A)
- Troubleshooting during operation (refer to Table 6.B)

 **WARNING**

ALL MAINTENANCE PROCEDURES MUST BE PERFORMED ONLY BY QUALIFIED PERSONNEL WHO ARE FAMILIAR WITH THE IQ DP-4000 AND ITS USES. FAILURE TO OBSERVE THIS WARNING COULD RESULT IN SERIOUS INJURY, DEATH, AND/OR EQUIPMENT DAMAGE.

TROUBLESHOOTING PROCEDURES MAY INVOLVE WORKING ON EQUIPMENT IN AREAS WITH EXPOSED LIVE PARTS WHERE THE HAZARD OF A FATAL ELECTRIC SHOCK IS PRESENT. PERSONNEL MUST EXERCISE EXTREME CAUTION TO AVOID INJURY OR EVEN DEATH.

ALWAYS DISCONNECT AND LOCK OUT THE CURRENT SOURCE AND CONTROL POWER SUPPLY BEFORE TOUCHING THE COMPONENTS ON THE REAR OF THE IQ DP-4000.

6.4 REPLACEMENT

To replace the IQ DP-4000:

1. Turn off control power at the main disconnect or isolation switch of the power supply. If the switch is not located in view of the IQ DP-4000, lock it out to guard against other personnel accidentally turning on the switch.
2. Verify that all “foreign” power sources wired to the IQ DP-4000 are de-energized. These sources may also be present on the relay and the input/output terminal block. Temporarily short the current transformer (CT) inputs at a point prior to the IQ DP-4000’s terminals before attempting to open the terminals on the IQ DP-4000.
3. Before disconnecting any wires from the unit, you must individually identify them to assure that you can reconnect them properly. Make a sketch to aid in terminal and wire identification.
4. If an optional ribbon cable connects with the communication port, carefully disconnect it.
5. If the power module for the unit is in a remote location, carefully unplug the optional extension cable from the IQ DP-4000 chassis, not from the power module. Remove the wires by loosening the wire connection at the screw terminal.

 **WARNING**

SUPPORT THE IQ DP-4000 FROM THE FRONT SIDE WHEN THE SCREWS ARE LOOSENED OR REMOVED IN STEP 6. WITHOUT SUCH SUPPORT, THE UNIT COULD FALL OR THE PANEL COULD BE DAMAGED.

6. Remove the mounting screws holding the unit against the door or panel. The screws are accessible from the rear of the unit. Carefully lay the screws aside for later use.
7. Remove the present unit and mount the replacement unit.
8. To connect the replacement unit, reverse the procedure outlined in steps 4 - 7.
9. Use the sketch you made in step 3 to replace each wire at the correct terminal.
10. Go to Section 4.5 and perform initial startup.

6.5 TECHNICAL ASSISTANCE

For information, technical assistance, or referral to an authorized distributor, contact Cutler-Hammer

Advanced Products Support Center (APSC) at 1-800-809-2772.

Symptom	Probable Cause(s)	Solution
All Operator Panel indicators are off.	AC line voltage level is deficient.	Locate cause of deficiency in AC line monitored.
	Separate Source AC control power is deficient (only if using separate source power module).	Locate the cause of the deficiency in the AC control power line. If power is sufficient, replace unit.
	AC line, or optional, external PTs are not properly selected, wired, or installed.	Verify that the AC line and/or PTs are wired as shown on the wiring plan drawings for the application.
Digit 1 flashes in the display window, indicating an external trip.	A trip condition has been externally initiated through the Communications Port.	Determine why the trip was initiated from the external device through the Communications Option.
Digit 2 flashes in the display window indicating an overvoltage	AC line, or optional, external PTs are not properly installed or wired.	Verify that the AC line, and PTs are installed and wired as shown on the wiring plan drawing for the application.
Digit 3 flashes in the display window, indicating an undervoltage.	An Undervoltage condition actually exists.	Isolate the AC line deficiency's cause.
Digit 4 flashes in the display window, indicating a phase unbalance.	A Phase Unbalance condition exists.	Isolate the cause of the AC line deficiency.
Digit 5 flashes in the display window, indicating a voltage phase loss.	A Voltage Phase Loss condition exists.	Isolate the cause of the AC line phase cause.
	Blown or loose fuse(s).	Check the fuse(s) on the affected phase(s). Reseat fuse(s). Replace if necessary.
Digit 6 flashes in the display window, indicating a current phase loss.	A Current Phase Loss condition exists.	Correct the improper wiring.
Digit 7 flashes in display window, indicating a phase reversal.	A Phase Reversal condition exists.	Isolate the cause of the AC line reversal. Check the utility to determine their phase sequence.
Digit 8 flashes in display window, indicating an internal malfunction.	IQ DP-4000 is detecting an internal malfunction.	Replace the unit.
One or more voltage phases read incorrectly.	Blown or loose fuse(s).	Check fuse(s) on the affected phase(s). Reseat the fuse(s). Replace if necessary.
	Incorrect PT ratio.	Check PT ratio.
Current readings are not accurate or read zero.	Incorrect size CTs used.	Replace with proper size CTs.
	Incorrect CT ratio.	Check CT ratio.
Power readings are incorrect.	Phasing for voltage and current is incorrect.	Check phasing. Verify connections with wiring diagrams.

Table 6.A Initial Power-On Troubleshooting

Symptom	Probable Cause(s)	Solution
All Operator Panel LEDs are off.	AC line being monitored is below 96 VAC.	Locate the cause of the deficiency in the monitored AC line.
	Separate Source AC line voltage is deficient.	Locate the cause of the deficiency in the AC control power line.
	AC line fuses are blown, missing, or not contacting correctly.	Verify that the incoming AC line is at the correct voltage level. Check that the fuses are sitting correctly in their clips.
	IQ DP-4000 is malfunctioning.	Replace the unit.
Digit 1 flashes in the display window.	A trip condition has been externally initiated through the Communications Port.	Determine why the trip was initiated from the external device through the Communications Port.
Digit 2 flashes in the display window.	An overvoltage condition is detected.	Isolate the cause in the line.
Digit 3 flashes in the display window.	An undervoltage condition is detected.	Isolate the cause in the line.
Digit 4 flashes in the display window.	A phase unbalance condition is detected.	Isolate the cause in the line.
Digit 5 flashes in the display window.	A voltage phase loss condition is detected.	Isolate the cause in the line.
	Blown or loose fuse(s).	Check fuse(s) on affected phase(s). Reseat the fuse(s). Replace the fuse(s) if necessary.
Digit 6 flashes in the display window.	A current phase loss condition is detected.	Isolate the cause of the AC current phase loss.
Digit 7 flashes in the display window.	The IQ DP-4000 is detecting a phase reversal.	Isolate the cause of the AC line phase reversal.
Digit 8 flashes in the display window.	The IQ DP-4000 is detecting an internal malfunction.	Replace the unit.
One or more voltage phases read incorrectly	Blown or loose fuse(s).	Check fuse(s) on affected phase(s). Reseat the fuse(s). Replace the fuse(s) if necessary.
	Incorrect PT ratio.	Check PT ratio.
Current readings are not accurate or read zero.	Incorrect size CTs used.	Replace with proper size CTs.
	Incorrect CT ratio.	Check CT ratio.
Power readings are incorrect.	Phasing for voltage and current is incorrect.	Check phasing. Verify connections with wiring diagrams.

Table 6.B Operational Troubleshooting

6.6 RETURN PROCEDURE

The troubleshooting section is intended for service personnel to identify whether an observed problem is external or internal to the unit. For assistance with this determination, please contact Advanced Product Support (APSC) at 1-800-809-2772. If a problem is identified as internal, return the unit to the factory for repair or replacement. To return your unit, contact your local Cutler-Hammer authorized distributor.

= OFF = ON

PT Values		Switch Settings								
PT Ratio	Select Switch	SW1	SW2	SW2	SW2	SW2	SW2	SW2	SW2	SW2
(PT:1)	Setpoint Switch	No. 7	No. 1	No. 2	No. 3	No. 4	No. 5	No. 6	No. 7	No. 8
1										
1.1										
1.2										
1.3										
1.4										
1.5										
1.6										
1.7										
1.8										
1.9										
2										
2.1										
2.2										
2.3										
2.4										
2.5										
2.6										
2.7										
2.8										
2.9										
3.0										
3.1										
3.2										
3.3										
3.4										
3.5										
3.6										
3.7										
3.8										
3.9										
4.0										
4.1										
4.2										
4.3										
4.4										
4.5										

= OFF = ON

PT Values		Switch Settings								
PT Ratio	Select Switch	SW1	SW2	SW2	SW2	SW2	SW2	SW2	SW2	SW2
(PT:1)	Setpoint Switch	No. 7	No. 1	No. 2	No. 3	No. 4	No. 5	No. 6	No. 7	No. 8
4.6										
4.7										
4.8										
4.9										
5.0										
5.1										
5.2										
5.3										
5.4										
5.5										
5.6										
5.7										
5.8										
5.9										
6										
7										
8										
9										
10										
11										
12										
13										
14										
15										
16										
17										
18										
19										
20										
25										
30										
35										
40										
45										
50										
55										
60										

= OFF = ON

PT Values		Switch Settings								
PT Ratio (PT:1)	Select Switch	SW1	SW2	SW2	SW2	SW2	SW2	SW2	SW2	SW2
	Setpoint Switch	No. 7	No. 1	No. 2	No. 3	No. 4	No. 5	No. 6	No. 7	No. 8
65										
70										
75										
80										
85										
90										
95										
100										
105										
110										
115										
120										
125										
130										
135										
140										
145										
150										
155										
160										
165										
170										
175										
180										
185										
190										
195										
200										
205										
210										
215										
220										
225										
230										
235										
240										
245										
250										
255										
260										

= OFF = ON

PT		Switch Settings								
Values		Select Switch	SW1	SW2	SW2	SW2	SW2	SW2	SW2	SW2
PT Ratio (PT:1)	Setpoint Switch	No. 7	No. 1	No. 2	No. 3	No. 4	No. 5	No. 6	No. 7	No. 8
270										
280										
290										
300										
310										
320										
330										
340										
350										
360										
370										
380										
390										
400										
410										
420										
430										
440										
450										
460										
470										
480										
490										
500										
510										
520										
530										
540										
550										
560										
570										
580										
590										
600										
610										
620										
630										
640										

= OFF = ON

PT		Switch Settings								
Values		Select Switch	SW1	SW2	SW2	SW2	SW2	SW2	SW2	SW2
PT Ratio (PT:1)	Setpoint Switch	No. 7	No. 1	No. 2	No. 3	No. 4	No. 5	No. 6	No. 7	No. 8
650										
660										
670										
680										
690										
700										
710										
720										
730										
740										
750										
760										
770										
780										
790										
800										
810										
820										
830										
840										
850										
860										
870										
880										
890										
900										
910										
920										
930										
940										
950										
960										
970										
980										
990										
1000										
1010										
1020										

= OFF = ON

PT Values		Switch Settings								
PT Ratio (PT:1)	Select Switch	SW1	SW2	SW2	SW2	SW2	SW2	SW2	SW2	SW2
	Setpoint Switch	No. 7	No. 1	No. 2	No. 3	No. 4	No. 5	No. 6	No. 7	No. 8
1030		■	□	■	□	□	□	□	■	□
1040		■	■	□	□	□	□	□	■	□
1050		■	□	□	□	□	□	□	■	□
1060		■	■	■	■	■	■	■	□	□
1070		■	□	■	■	■	■	■	□	□
1080		■	■	□	■	■	■	■	□	□
1090		■	□	■	■	■	■	■	□	□
1100		■	■	■	□	■	■	■	□	□
1110		■	■	■	□	■	■	■	□	□
1120		■	■	□	□	■	■	■	□	□
1130		■	□	□	□	■	■	■	□	□
1140		■	■	■	■	□	■	■	□	□
1150		■	■	■	■	□	■	■	□	□
1160		■	■	□	■	■	■	■	□	□
1170		■	□	■	■	■	■	■	□	□
1180		■	■	□	□	■	■	■	□	□
1190		■	□	■	□	■	■	■	□	□
1200		■	■	□	□	□	■	■	□	□
1210		■	□	□	□	□	■	■	□	□
1220		■	■	■	■	■	□	■	□	□
1230		■	■	■	■	■	□	■	□	□
1240		■	■	□	■	■	■	■	□	□
1250		■	□	□	■	■	■	■	□	□
1260		■	■	■	■	■	□	■	□	□
1270		■	□	■	□	■	■	■	□	□
1280		■	■	□	□	■	■	■	□	□
1290		■	□	□	□	■	■	■	□	□
1300		■	■	■	■	□	■	■	□	□
1310		■	□	■	■	□	■	■	□	□
1320		■	■	□	■	■	□	■	□	□
1330		■	□	□	■	■	□	■	□	□
1340		■	■	■	□	□	■	■	□	□
1350		■	□	■	□	□	■	■	□	□
1360		■	■	□	□	□	■	■	□	□
1370		■	□	□	□	□	□	■	□	□
1380		■	■	■	■	■	■	□	□	□
1390		■	□	■	■	■	■	□	□	□
1400		■	■	□	□	□	■	□	□	□

= OFF = ON

PT Values		Switch Settings								
PT Ratio (PT:1)	Select Switch	SW1	SW2	SW2	SW2	SW2	SW2	SW2	SW2	SW2
	Setpoint Switch	No. 7	No. 1	No. 2	No. 3	No. 4	No. 5	No. 6	No. 7	No. 8
1410										
1420										
1430										
1440										
1450										
1460										
1470										
1480										
1490										
1500										
1510										
1520										
1530										
1540										
1550										
1560										
1570										
1580										
1590										
1600										
1610										
1620										
1630										
1640										
1650										
1660										
1670										
1680										
1690										
1700										
1710										
1720										
1730										
1740										
1750										
1760										
1770										
1780										

= OFF = ON

PT Values		Switch Settings								
PT Ratio (PT:1)	Select Switch	SW1	SW2	SW2	SW2	SW2	SW2	SW2	SW2	SW2
	Setpoint Switch	No. 7	No. 1	No. 2	No. 3	No. 4	No. 5	No. 6	No. 7	No. 8
1790										
1800										
1810										
1820										
1830										
1840										
1850										
1860										
1870										
1880										
1890										
1900										
1910										
1920										
1930										
1940										
1950										
1960										
1970										
1980										
1990										
2000										
2010										
2020										
2030										
2040										
2050										
2060										
2070										
2080										
2090										
2100										
2110										
2120										
2130										
2140										
2150										

= OFF = ON

PT Values		Switch Settings								
PT Ratio (PT:1)	Select Switch	SW1	SW2	SW2	SW2	SW2	SW2	SW2	SW2	SW2
	Setpoint Switch	No. 7	No. 1	No. 2	No. 3	No. 4	No. 5	No. 6	No. 7	No. 8
2160			■				■		■	
2170			■				■		■	
2180			■	■	■	■	■			
2190			■	■	■	■				
2200			■	■	■	■				
2210			■	■	■	■				
2220			■	■	■	■				
2230			■	■	■	■				
2240			■	■	■	■				
2250			■	■	■	■				
2260			■	■	■	■				
2270			■	■	■	■				
2280			■	■	■	■				
2290			■	■	■	■				
2300			■	■	■	■				
2310			■	■	■	■				
2320			■	■	■	■				
2330			■	■	■	■				
2340			■	■	■	■	■	■		
2350			■	■	■	■	■	■		
2360			■	■	■	■	■	■		
2370			■	■	■	■	■	■		
2380			■	■	■	■	■	■		
2390			■	■	■	■	■	■		
2400			■	■	■	■	■	■		
2410			■	■	■	■	■	■		
2420			■	■	■	■	■	■		
2430			■	■	■	■	■	■		
2440			■	■	■	■	■	■		
2450			■	■	■	■	■	■		
2460			■	■	■	■	■	■		
2470			■	■	■	■	■	■		
2480			■	■	■	■	■	■		
2490			■	■	■	■	■	■		
2500			■	■	■	■	■	■		
2510			■	■	■	■	■	■		
2520			■	■	■	■	■	■		

= OFF = ON

PT Values		Switch Settings								
PT Ratio (PT:1)	Select Switch	SW1	SW2	SW2	SW2	SW2	SW2	SW2	SW2	SW2
	Setpoint Switch	No. 7	No. 1	No. 2	No. 3	No. 4	No. 5	No. 6	No. 7	No. 8
2530										
2540										
2550										
2560										
2570										
2580										
2590										
2600										
2610										
2620										
2630										
2640										
2650										
2660										
2670										
2680										
2690										
2700										
2710										
2720										
2730										
2740										
2750										
2760										
2770										
2780										
2790										
2800										
2810										
2820										
2830										
2840										
2850										
2860										
2870										
2880										
2890										

= OFF = ON

PT Values		Switch Settings								
PT Ratio (PT:1)	Select Switch	SW1	SW2	SW2	SW2	SW2	SW2	SW2	SW2	SW2
	Setpoint Switch	No. 7	No. 1	No. 2	No. 3	No. 4	No. 5	No. 6	No. 7	No. 8
2900			■	■	■					■
2910			■	■	■					■
2920			■	■	■					■
2930			■	■	■					■
2940			■	■	■					■
2950			■	■	■					■
2960			■	■	■					■
2970			■	■	■					■
2980			■	■	■	■	■	■	■	■
2990			■	■	■	■	■	■	■	■
3000			■	■	■	■	■	■	■	■
3010			■	■	■	■	■	■	■	■
3020			■	■	■	■	■	■	■	■
3030			■	■	■	■	■	■	■	■
3040			■	■	■	■	■	■	■	■
3050			■	■	■	■	■	■	■	■
3060			■	■	■	■	■	■	■	■
3070			■	■	■	■	■	■	■	■
3080			■	■	■	■	■	■	■	■
3090			■	■	■	■	■	■	■	■
3100			■	■	■	■	■	■	■	■
3110			■	■	■	■	■	■	■	■
3120			■	■	■	■	■	■	■	■
3130			■	■	■	■	■	■	■	■
3140			■	■	■	■	■	■	■	■
3150			■	■	■	■	■	■	■	■
3160			■	■	■	■	■	■	■	■
3170			■	■	■	■	■	■	■	■
3180			■	■	■	■	■	■	■	■
3190			■	■	■	■	■	■	■	■
3200			■	■	■	■	■	■	■	■
3210			■	■	■	■	■	■	■	■
3220			■	■	■	■	■	■	■	■
3230			■	■	■	■	■	■	■	■
3240			■	■	■	■	■	■	■	■
3250			■	■	■	■	■	■	■	■

= OFF = ON

PT Values		Switch Settings								
PT Ratio (PT:1)	Select Switch	SW1	SW2	SW2	SW2	SW2	SW2	SW2	SW2	SW2
	Setpoint Switch	No. 7	No. 1	No. 2	No. 3	No. 4	No. 5	No. 6	No. 7	No. 8
3260			■	■				■	■	
3270			■	■				■	■	
3280			■	■				■	■	
3290			■	■				■	■	
3300			■	■	■	■	■	■	■	
3310			■	■	■	■	■	■	■	
3320			■	■	■	■	■	■	■	
3330			■	■	■	■	■	■	■	
3340			■	■	■	■	■	■	■	
3350			■	■	■	■	■	■	■	
3360			■	■	■	■	■	■	■	
3370			■	■	■	■	■	■	■	
3380			■	■	■	■	■	■	■	
3390			■	■	■	■	■	■	■	
3400			■	■	■	■	■	■	■	
3410			■	■	■	■	■	■	■	
3420			■	■	■	■	■	■	■	
3430			■	■	■	■	■	■	■	
3440			■	■	■	■	■	■	■	
3450			■	■	■	■	■	■	■	
3460			■	■	■	■	■	■	■	
3470			■	■	■	■	■	■	■	
3480			■	■	■	■	■	■	■	
3490			■	■	■	■	■	■	■	
3500			■	■	■	■	■	■	■	
3510			■	■	■	■	■	■	■	
3520			■	■	■	■	■	■	■	
3530			■	■	■	■	■	■	■	
3540			■	■	■	■	■	■	■	
3550			■	■	■	■	■	■	■	
3560			■	■	■	■	■	■	■	
3570			■	■	■	■	■	■	■	
3580			■	■	■	■	■	■	■	
3590			■	■	■	■	■	■	■	
3600			■	■	■	■	■	■	■	
3610			■	■	■	■	■	■	■	

= OFF = ON

PT Values		Switch Settings								
PT Ratio (PT:1)	Select Switch	SW1	SW2	SW2	SW2	SW2	SW2	SW2	SW2	SW2
	Setpoint Switch	No. 7	No. 1	No. 2	No. 3	No. 4	No. 5	No. 6	No. 7	No. 8
3620			■	■	■	■	■	■		
3630			■	■	■	■	■	■		
3640			■	■	■	■	■	■		
3650			■	■	■	■	■	■		
3660			■	■	■	■	■	■		
3670			■	■	■	■	■	■		
3680			■	■	■	■	■	■		
3690			■	■	■	■	■	■		
3700			■	■	■	■	■	■		
3710			■	■	■	■	■	■		
3720			■	■	■	■	■	■		
3730			■	■	■	■	■	■		
3740			■	■	■	■	■	■		
3750			■	■	■	■	■	■		
3760			■	■	■	■	■	■		
3770			■	■	■	■	■	■		
3780			■	■	■	■	■	■		
3790			■	■	■	■	■	■		
3800			■	■	■	■	■	■		
3810			■	■	■	■	■	■		
3820			■	■	■	■	■	■		
3830			■	■	■	■	■	■		
3840			■	■	■	■	■	■		
3850			■	■	■	■	■	■		
3860			■	■	■	■	■	■		
3870			■	■	■	■	■	■		
3880			■	■	■	■	■	■		
3890			■	■	■	■	■	■		
3900			■	■	■	■	■	■		
3910			■	■	■	■	■	■		
3920			■	■	■	■	■	■		
3930			■	■	■	■	■	■		
3940			■	■	■	■	■	■		
3950			■	■	■	■	■	■		
3960			■	■	■	■	■	■		
3970			■	■	■	■	■	■		

= OFF = ON

PT Values		Switch Settings								
PT Ratio (PT:1)	Select Switch	SW1	SW2	SW2	SW2	SW2	SW2	SW2	SW2	SW2
	Setpoint Switch	No. 7	No. 1	No. 2	No. 3	No. 4	No. 5	No. 6	No. 7	No. 8
3980			■	■		■	■			
3990			■	■		■	■			
4000			■			■	■			
4010			■			■	■			
4020			■	■	■		■			
4030			■	■	■		■			
4040			■		■		■			
4050			■		■		■			
4060			■	■			■			
4070			■	■			■			
4080			■				■			
4090			■				■			
4100			■	■	■	■				
4110			■	■	■	■				
4120			■		■	■				
4130			■		■	■				
4140			■	■		■				
4150			■	■		■				
4160			■			■				
4170			■			■				
4180			■	■	■					
4190			■	■	■					
4200			■		■					
4210			■		■					
4220			■	■						
4230			■	■						
4240			■							
4250			■							

= OFF = ON

CT Values		Switch Settings								
CT Primary (CT:5)	Select Switch	SW1	SW3	SW3	SW3	SW3	SW3	SW3	SW3	SW3
	Setpoint Switch	No. 8	No. 1	No. 2	No. 3	No. 4	No. 5	No. 6	No. 7	No. 8
5										
10										
15										
20										
25										
30										
35										
40										
45										
50										
55										
60										
65										
70										
75										
80										
85										
90										
95										
100										
105										
110										
115										
120										
125										
130										
135										
140										
145										
150										
155										
160										
165										
170										
175										
180										

= OFF = ON

CT Values		Switch Settings								
CT Primary (CT:5)	Select Switch	SW1	SW3	SW3	SW3	SW3	SW3	SW3	SW3	SW3
	Setpoint Switch	No. 8	No. 1	No. 2	No. 3	No. 4	No. 5	No. 6	No. 7	No. 8
185										
190										
195										
200										
205										
210										
215										
220										
225										
230										
235										
240										
245										
250										
255										
260										
265										
270										
275										
280										
285										
290										
295										
300										
305										
310										
315										
320										
325										
330										
335										
340										
345										
350										
355										
360										
365										

= OFF = ON

CT		Switch Settings								
Values		Select Switch	SW1	SW3	SW3	SW3	SW3	SW3	SW3	SW3
CT Primary (CT:5)	Setpoint Switch	No. 8	No. 1	No. 2	No. 3	No. 4	No. 5	No. 6	No. 7	No. 8
370										
375										
380										
385										
390										
395										
400										
405										
410										
415										
420										
425										
430										
435										
440										
445										
450										
455										
460										
465										
470										
475										
480										
485										
490										
495										
500										
505										
510										
515										
520										
525										
530										
535										
540										
545										
550										
555										
560										
565										

= OFF = ON

CT Values		Switch Settings								
CT Primary (CT:5)	Select Switch	SW1	SW3	SW3	SW3	SW3	SW3	SW3	SW3	SW3
	Setpoint Switch	No. 8	No. 1	No. 2	No. 3	No. 4	No. 5	No. 6	No. 7	No. 8
570										
575										
580										
585										
590										
595										
600										
605										
610										
615										
620										
625										
630										
635										
640										
645										
650										
655										
660										
665										
670										
675										
680										
685										
690										
695										
700										
705										
710										
715										
720										
725										
730										
735										
740										
745										
750										
755										

= OFF = ON

CT Values		Switch Settings								
CT Primary (CT:5)	Select Switch	SW1	SW3	SW3	SW3	SW3	SW3	SW3	SW3	SW3
	Setpoint Switch	No. 8	No. 1	No. 2	No. 3	No. 4	No. 5	No. 6	No. 7	No. 8
760										
765										
770										
775										
780										
785										
790										
795										
800										
805										
810										
815										
820										
825										
830										
835										
840										
845										
850										
855										
860										
865										
870										
875										
880										
885										
890										
895										
900										
905										
910										
915										
920										
925										
930										
935										
940										
945										

= OFF = ON

CT		Switch Settings								
Values		Select Switch	SW1	SW3	SW3	SW3	SW3	SW3	SW3	SW3
CT Primary (CT:5)	Setpoint Switch	No. 8	No. 1	No. 2	No. 3	No. 4	No. 5	No. 6	No. 7	No. 8
950										
955										
960										
965										
970										
975										
980										
985										
990										
995										
1000										
1005										
1010										
1015										
1020										
1025										
1030										
1035										
1040										
1045										
1050										
1055										
1060										
1065										
1070										
1075										
1080										
1085										
1090										
1095										
1100										
1105										
1110										
1115										
1120										
1125										
1130										
1135										

= OFF = ON

CT		Switch Settings								
Values										
CT Primary (CT:5)	Select Switch	SW1	SW3	SW3	SW3	SW3	SW3	SW3	SW3	SW3
	Setpoint Switch	No. 8	No. 1	No. 2	No. 3	No. 4	No. 5	No. 6	No. 7	No. 8
1140										
1145										
1150										
1155										
1160										
1165										
1170										
1175										
1180										
1185										
1190										
1195										
1200										
1205										
1210										
1215										
1220										
1225										
1230										
1235										
1240										
1245										
1250										
1255										
1260										
1265										
1270										
1275										
1280										
*50										
*100										
*150										
*200										
*250										
*300										
*350										
*400										
*450										

* These CT Primary values are repeated from previous pages. Either setting is acceptable.

= OFF = ON

CT Values		Switch Settings								
CT Primary (CT:5)	Select Switch	SW1	SW3	SW3	SW3	SW3	SW3	SW3	SW3	SW3
	Setpoint Switch	No. 8	No. 1	No. 2	No. 3	No. 4	No. 5	No. 6	No. 7	No. 8
*500										
*550										
*600										
*650										
*700										
*750										
*800										
*850										
*900										
*950										
*1000										
*1050										
*1100										
*1150										
*1200										
*1250										
1300										
1350										
1400										
1450										
1500										
1550										
1600										
1650										
1700										
1750										
1800										
1850										
1900										
1950										
2000										
2050										
2100										
2150										
2200										
2250										
2300										

* These CT Primary values are repeated from previous pages. Either setting is acceptable

= OFF = ON

CT		Switch Settings								
Values										
CT Primary (CT:5)	Select Switch	SW1	SW3	SW3	SW3	SW3	SW3	SW3	SW3	SW3
	Setpoint Switch	No. 8	No. 1	No. 2	No. 3	No. 4	No. 5	No. 6	No. 7	No. 8
2350			■					■		
2400								■		
2450			■	■	■	■				
2500				■						
2550			■		■					
2600					■	■				
2650			■	■		■				
2700				■		■				
2750			■			■				
2800						■				
2850			■	■	■					
2900				■	■					
2950			■		■					
3000					■					
3050			■	■						
3100				■						
3150			■							
3200										
3250			■	■	■	■	■			
3300										
3350			■							
3400					■					
3450			■	■						
3500										
3550			■	■						
3600						■				
3650			■	■	■					
3700					■					
3750			■		■					
3800					■					
3850			■	■						
3900				■						
3950			■							
4000										
4050			■	■	■	■				
4100				■	■					
4150			■		■	■				

= OFF = ON

CT Values		Switch Settings								
CT Primary (CT:5)	Select Switch	SW1	SW3	SW3	SW3	SW3	SW3	SW3	SW3	SW3
	Setpoint Switch	No. 8	No. 1	No. 2	No. 3	No. 4	No. 5	No. 6	No. 7	No. 8
4200										
4250										
4300										
4350										
4400										
4450										
4500										
4550										
4600										
4650										
4700										
4750										
4800										
4850										
4900										
4950										
5000										
5050										
5100										
5150										
5200										
5250										
5300										
5350										
5400										
5450										
5500										
5550										
5600										
5650										
5700										
5750										
5800										
5850										
5900										
5950										
6000										

= OFF = ON

CT Values		Switch Settings								
CT Primary (CT:5)	Select Switch	SW1	SW3	SW3	SW3	SW3	SW3	SW3	SW3	SW3
	Setpoint Switch	No. 8	No. 1	No. 2	No. 3	No. 4	No. 5	No. 6	No. 7	No. 8
6050			■	■	■					■
6100			■	■	■					■
6150			■	■	■					■
6200			■	■	■					■
6250			■	■	■					■
6300			■	■	■					■
6350			■	■	■					■
6400			■	■	■					■
6450			■	■	■	■	■	■	■	■
6500			■	■	■	■	■	■	■	■
6550			■	■	■	■	■	■	■	■
6600			■	■	■	■	■	■	■	■
6650			■	■	■	■	■	■	■	■
6700			■	■	■	■	■	■	■	■
6750			■	■	■	■	■	■	■	■
6800			■	■	■	■	■	■	■	■
6850			■	■	■	■	■	■	■	■
6900			■	■	■	■	■	■	■	■
6950			■	■	■	■	■	■	■	■
7000			■	■	■	■	■	■	■	■
7050			■	■	■	■	■	■	■	■
7100			■	■	■	■	■	■	■	■
7150			■	■	■	■	■	■	■	■
7200			■	■	■	■	■	■	■	■
7250			■	■	■	■	■	■	■	■
7300			■	■	■	■	■	■	■	■
7350			■	■	■	■	■	■	■	■
7400			■	■	■	■	■	■	■	■
7450			■	■	■	■	■	■	■	■
7500			■	■	■	■	■	■	■	■
7550			■	■	■	■	■	■	■	■
7600			■	■	■	■	■	■	■	■
7650			■	■	■	■	■	■	■	■
7700			■	■	■	■	■	■	■	■
7750			■	■	■	■	■	■	■	■
7800			■	■	■	■	■	■	■	■

= OFF = ON

CT Values		Switch Settings								
CT Primary (CT:5)	Select Switch	SW1	SW3	SW3	SW3	SW3	SW3	SW3	SW3	SW3
	Setpoint Switch	No. 8	No. 1	No. 2	No. 3	No. 4	No. 5	No. 6	No. 7	No. 8
7850			■	■				■	■	
7900			■	■				■	■	
7950			■	■				■	■	
8000			■	■				■	■	
8050			■	■	■	■	■	■	■	
8100			■	■	■	■	■	■	■	
8150			■	■	■	■	■	■	■	
8200			■	■	■	■	■	■	■	
8250			■	■	■	■	■	■	■	
8300			■	■	■	■	■	■	■	
8350			■	■	■	■	■	■	■	
8400			■	■	■	■	■	■	■	
8450			■	■	■	■	■	■	■	
8500			■	■	■	■	■	■	■	
8550			■	■	■	■	■	■	■	
8600			■	■	■	■	■	■	■	
8650			■	■	■	■	■	■	■	
8700			■	■	■	■	■	■	■	
8750			■	■	■	■	■	■	■	
8800			■	■	■	■	■	■	■	
8850			■	■	■	■	■	■	■	
8900			■	■	■	■	■	■	■	
8950			■	■	■	■	■	■	■	
9000			■	■	■	■	■	■	■	
9050			■	■	■	■	■	■	■	
9100			■	■	■	■	■	■	■	
9150			■	■	■	■	■	■	■	
9200			■	■	■	■	■	■	■	
9250			■	■	■	■	■	■	■	
9300			■	■	■	■	■	■	■	
9350			■	■	■	■	■	■	■	
9400			■	■	■	■	■	■	■	
9450			■	■	■	■	■	■	■	
9500			■	■	■	■	■	■	■	
9550			■	■	■	■	■	■	■	
9600			■	■	■	■	■	■	■	

= OFF = ON

CT Values		Switch Settings								
CT Primary (CT:5)	Select Switch	SW1	SW3	SW3	SW3	SW3	SW3	SW3	SW3	SW3
	Setpoint Switch	No. 8	No. 1	No. 2	No. 3	No. 4	No. 5	No. 6	No. 7	No. 8
9650			■	■	■	■	■	■		
9700			■	■	■	■	■	■		
9750			■	■	■	■	■	■		
9800			■	■	■	■	■	■		
9850			■	■	■	■	■	■		
9900			■	■	■	■	■	■		
9950			■	■	■	■	■	■		
10000			■	■	■	■	■	■		
10050			■	■	■	■	■	■		
10100			■	■	■	■	■	■		
10150			■	■	■	■	■	■		
10200			■	■	■	■	■	■		
10250			■	■	■	■	■	■		
10300			■	■	■	■	■	■		
10350			■	■	■	■	■	■		
10400			■	■	■	■	■	■		
10450			■	■	■	■	■	■		
10500			■	■	■	■	■	■		
10550			■	■	■	■	■	■		
10600			■	■	■	■	■	■		
10650			■	■	■	■	■	■		
10700			■	■	■	■	■	■		
10750			■	■	■	■	■	■		
10800			■	■	■	■	■	■		
10850			■	■	■	■	■	■		
10900			■	■	■	■	■	■		
10950			■	■	■	■	■	■		
11000			■	■	■	■	■	■		
11050			■	■	■	■	■	■		
11100			■	■	■	■	■	■		
11150			■	■	■	■	■	■		
11200			■	■	■	■	■	■		
11250			■	■	■	■	■	■		
11300			■	■	■	■	■	■		
11350			■	■	■	■	■	■		
11400			■	■	■	■	■	■		

= OFF = ON

CT		Switch Settings								
Values		SW1	SW3	SW3	SW3	SW3	SW3	SW3	SW3	SW3
CT Primary (CT:5)	Select Switch	No. 8	No. 1	No. 2	No. 3	No. 4	No. 5	No. 6	No. 7	No. 8
	Setpoint Switch									
11450			■	■		■	■			
11500			■	■		■	■			
11550			■			■	■			
11600			■			■	■			
11650			■	■	■		■			
11700			■	■	■		■			
11750			■		■		■			
11800			■		■		■			
11850			■	■			■			
11900			■	■			■			
11950			■				■			
12000			■				■			
12050			■	■	■	■				
12100			■	■	■	■				
12150			■		■	■				
12200			■		■	■				
12250			■	■		■				
12300			■	■		■				
12350			■			■				
12400			■			■				
12450			■	■	■					
12500			■	■	■					
12550			■		■					
12600			■	■	■					
12650			■	■						
12700			■	■						
12750			■							
12800										

Master Setpoint Record Sheet

Once you have determined the settings for your setpoint switches, record them in this table. Remove and store this table in several locations and keep it up-to-date when you change settings.

Select Switch	Setpoint Switches							
	No. 1	No. 2	No. 3.	No. 4	No. 5	No. 6	No. 7	No. 8
SW1								
SW2								
SW3								
SW4								
SW5			Not Used					
SW6								
SW7								
SW8								
SW9								
SWA								
SWB								
SWC								
SWD								
SWE								
SWF								

In the Setpoint Display rows, shade the cells of the numbers for which the LED's should light. This will allow you to easily verify the settings for each Select Switch. In the Setpoint Switch row, indicate beside each switch whether the switch is to the left (Off) or to the right (On). The ninth Setpoint Display is not used. The tenth lights only when you hold the Save button long enough (about four seconds) to save the settings for the current Select Switch.

Use the following pages to record your settings for each setpoint. They are organized by General System, Alarm 1, Alarm 2, and Optional I/O Setpoints.

This page contains the settings for Setpoint Switch 1 to 9. The settings for Switches A to F are on the next page.

	SW1	SW2	SW3	SW4	SW5	SW6	SW7	SW8	SW9
Setpoint Display	1.	1.	1.	1.	1.	1.	1.	1.	1.
	2.	2.	2.	2.	2.	2.	2.	2.	2.
	3.	3.	3.	3.	3.	3.	3.	3.	3.
	4.	4.	4.	4.	4.	4.	4.	4.	4.
	5.	5.	5.	5.	5.	5.	5.	5.	5.
	6.	6.	6.	6.	6.	6.	6.	6.	6.
	7.	7.	7.	7.	7.	7.	7.	7.	7.
	8.	8.	8.	8.	8.	8.	8.	8.	8.
Setpoint Switch	1.	1.	1.	1.	1.	1.	1.	1.	1.
	2.	2.	2.	2.	2.	2.	2.	2.	2.
	3.	3.	3.	3.	3.	3.	3.	3.	3.
	4.	4.	4.	4.	4.	4.	4.	4.	4.
	5.	5.	5.	5.	5.	5.	5.	5.	5.
	6.	6.	6.	6.	6.	6.	6.	6.	6.
	7.	7.	7.	7.	7.	7.	7.	7.	7.
	8.	8.	8.	8.	8.	8.	8.	8.	8.

	SWA	SWB	SWC	SWD	SWE	SWF
Setpoint	1.	1.	1.	1.	1.	1.
Display	2.	2.	2.	2.	2.	2.
	3.	3.	3.	3.	3.	3.
	4.	4.	4.	4.	4.	4.
	5.	5.	5.	5.	5.	5.
	6.	6.	6.	6.	6.	6.
	7.	7.	7.	7.	7.	7.
	8.	8.	8.	8.	8.	8.
Setpoint	1.	1.	1.	1.	1.	1.
Switch	2.	2.	2.	2.	2.	2.
	3.	3.	3.	3.	3.	3.
	4.	4.	4.	4.	4.	4.
	5.	5.	5.	5.	5.	5.
	6.	6.	6.	6.	6.	6.
	7.	7.	7.	7.	7.	7.
	8.	8.	8.	8.	8.	8.

General System Setpoint Record Sheet

System Configuration

■ = OFF □ = ON ▒ = Not Applicable

Select Switch	Setpoint Switch #							
Position	1	2	3	4	5	6	7	8
1		▒	▒	▒	▒	▒	▒	▒

OFF = 3-Wire

ON = 4-Wire

Voltage Transformer Ratio

■ = OFF □ = ON ▒ = Not Applicable

Select Switch	Setpoint Switch #							
Position	1	2	3	4	5	6	7	8
1	▒	▒	▒	▒	▒	▒		▒
2								

See Appendix A

Frequency Selection

■ = OFF □ = ON ▒ = Not Applicable

Select Switch	Setpoint Switch #							
Position	1	2	3	4	5	6	7	8
1	▒		▒	▒	▒	▒	▒	▒

OFF = 50 Hz

ON = 60 Hz

Current Transformer Primary

■ = OFF □ = ON ▒ = Not Applicable

Select Switch	Setpoint Switch #							
Position	1	2	3	4	5	6	7	8
1	▒	▒	▒	▒	▒	▒	▒	
3								

See Appendix A

Nominal AC Line Voltage

■ = OFF □ = ON ▒ = Not Applicable

Select Switch	Setpoint Switch #							
Position	1	2	3	4	5	6	7	8
1	▒	▒					▒	▒

See Table 5.F

Phase Sequence

■ = OFF □ = ON ▒ = Not Applicable

Select Switch	Setpoint Switch #							
Position	1	2	3	4	5	6	7	8
4		▒	▒	▒	▒	▒	▒	▒

OFF = ABC

ON = CBA

Power Demand Window

■ = OFF □ = ON ▒ = Not Applicable

Select Switch	Setpoint Switch #							
Position	1	2	3	4	5	6	7	8
4	▒	▒	▒	▒	▒	▒	▒	▒

OFF = Sliding

ON = Fixed

Reset Energy from Faceplate

■ = OFF □ = ON ▒ = Not Applicable

Select Switch	Setpoint Switch #							
Position	1	2	3	4	5	6	7	8
5	▒	▒	▒	▒	▒	▒	▒	▒

OFF = Disabled

ON = Enabled

Power Demand Time Interval

■ = OFF □ = ON ▒ = Not Applicable

Select Switch	Setpoint Switch #							
Position	1	2	3	4	5	6	7	8
4	▒	▒	▒	▒	▒	▒	▒	▒

See Table 5.G

Energy Resolution

■ = OFF □ = ON ▒ = Not Applicable

Select Switch	Setpoint Switch #							
Position	1	2	3	4	5	6	7	8
5	▒	▒	▒	▒	▒	▒	▒	▒

OFF = Kilo Units

ON = Mega Units

Current Demand Time Interval

■ = OFF □ = ON ▒ = Not Applicable

Select Switch	Setpoint Switch #							
Position	1	2	3	4	5	6	7	8
4	▒	▒	▒	▒	▒	▒	▒	▒

See Table 5.H

Var/Power Factor Sign Convention

■ = OFF □ = ON ▒ = Not Applicable

Select Switch	Setpoint Switch #							
Position	1	2	3	4	5	6	7	8
5	▒	▒	▒	▒	▒	▒	▒	▒

OFF = negative sign convention

ON = positive sign convention

INCOM Programmable

■ = OFF □ = ON ▒ = Not Applicable

Select Switch	Setpoint Switch #							
Position	1	2	3	4	5	6	7	8
C	▒	▒	▒	▒	▒	▒		▒

OFF = Disabled

ON = Enabled

DP-4000/DP-2 Mode

■ = OFF □ = ON ▒ = Not Applicable

Select Switch	Setpoint Switch #							
Position	1	2	3	4	5	6	7	8
C	▒	▒	▒	▒	▒	▒	▒	

OFF = DP2 Mode

ON = DP-4000 Mode

Alarm 1 Setpoint Record Sheet

Alarm 1 Mode 1/Mode 2

■ = OFF □ = ON ▒ = Not Applicable

Select Switch	Setpoint Switch #							
Position	1	2	3	4	5	6	7	8
6		▒	▒	▒	▒	▒	▒	▒

OFF = Mode 1

ON = Mode 2

Alarm 1 Activate on Undervoltage

■ = OFF □ = ON ▒ = Not Applicable

Select Switch	Setpoint Switch #							
Position	1	2	3	4	5	6	7	8
6	▒	▒	▒		▒	▒	▒	▒

OFF = Disabled

ON = Enabled

Alarm 1 Latched/Unlatched

■ = OFF □ = ON ▒ = Not Applicable

Select Switch	Setpoint Switch #							
Position	1	2	3	4	5	6	7	8
6	▒		▒	▒	▒	▒	▒	▒

OFF = Unlatched

ON = Latched

Alarm 1 Activate on Voltage Phase Loss

■ = OFF □ = ON ▒ = Not Applicable

Select Switch	Setpoint Switch #							
Position	1	2	3	4	5	6	7	8
6	▒	▒	▒	▒		▒	▒	▒

OFF = Disabled

ON = Enabled

Alarm 1 Activate on Overvoltage

■ = OFF □ = ON ▒ = Not Applicable

Select Switch	Setpoint Switch #							
Position	1	2	3	4	5	6	7	8
6	▒	▒		▒	▒	▒	▒	▒

OFF = Disabled

ON = Enabled

Alarm 1 Activate on Voltage Phase Unbalance

■ = OFF □ = ON ▒ = Not Applicable

Select Switch	Setpoint Switch #							
Position	1	2	3	4	5	6	7	8
6	▒	▒	▒	▒	▒		▒	▒

OFF = Disabled

ON = Enabled

Alarm 1 Activate on Voltage Phase Reversal

■ = OFF □ = ON ■ = Not Applicable

Select Switch	Setpoint Switch #							
Position	1	2	3	4	5	6	7	8
6								

OFF = Disabled

ON = Enabled

Alarm 1 Activate on Current Phase Loss

■ = OFF □ = ON ■ = Not Applicable

Select Switch	Setpoint Switch #							
Position	1	2	3	4	5	6	7	8
6								

OFF = Disabled

ON = Enabled

Alarm 1 Enable/Disable

■ = OFF □ = ON ■ = Not Applicable

Select Switch	Setpoint Switch #							
Position	1	2	3	4	5	6	7	8
8								

OFF = Disabled

ON = Enabled

Alarm 1 Trip Delay

■ = OFF □ = ON ■ = Not Applicable

Select Switch	Setpoint Switch #							
Position	1	2	3	4	5	6	7	8
8								

See Table 5.R

Alarm 1 Reset Delay

■ = OFF □ = ON ■ = Not Applicable

Select Switch	Setpoint Switch #							
Position	1	2	3	4	5	6	7	8
8								

See Table 5.S

Alarm 1 Overvoltage Detection Level

■ = OFF □ = ON ■ = Not Applicable

Select Switch	Setpoint Switch #							
Position	1	2	3	4	5	6	7	8
8								
9								

See Table 5.T

Alarm 1 Undervoltage Detection Level

■ = OFF □ = ON ▒ = Not Applicable

Select Switch	Setpoint Switch #								
	Position	1	2	3	4	5	6	7	8
9	▒	▒				▒	▒	▒	

See Table 5.U

Alarm 1 Reset Threshold

■ = OFF □ = ON ▒ = Not Applicable

Select Switch	Setpoint Switch #								
	Position	1	2	3	4	5	6	7	8
C				▒	▒	▒	▒	▒	▒

See Table 5.W

Alarm 1 Voltage Phase Unbalance Detection Level

■ = OFF □ = ON ▒ = Not Applicable

Select Switch	Setpoint Switch #								
	Position	1	2	3	4	5	6	7	8
9	▒	▒	▒	▒	▒				

See Table 5.V

Alarm 2 Setpoint Record Sheet

Alarm 2 Mode 1/Mode 2

■ = OFF □ = ON ▒ = Not Applicable

Select Switch	Setpoint Switch #							
Position	1	2	3	4	5	6	7	8
7		▒	▒	▒	▒	▒	▒	▒

OFF = Mode 1

ON = Mode 2

Alarm 2 Activate on Undervoltage

■ = OFF □ = ON ▒ = Not Applicable

Select Switch	Setpoint Switch #							
Position	1	2	3	4	5	6	7	8
7	▒	▒	▒		▒	▒	▒	▒

OFF = Disabled

ON = Enabled

Alarm 2 Latched/Unlatched

■ = OFF □ = ON ▒ = Not Applicable

Select Switch	Setpoint Switch #							
Position	1	2	3	4	5	6	7	8
7	▒		▒	▒	▒	▒	▒	▒

OFF = Unlatched

ON = Latched

Alarm 2 Activate on Voltage Phase Loss

■ = OFF □ = ON ▒ = Not Applicable

Select Switch	Setpoint Switch #							
Position	1	2	3	4	5	6	7	8
7	▒	▒	▒	▒		▒	▒	▒

OFF = Disabled

ON = Enabled

Alarm 2 Activate on Overvoltage

■ = OFF □ = ON ▒ = Not Applicable

Select Switch	Setpoint Switch #							
Position	1	2	3	4	5	6	7	8
7	▒	▒		▒	▒	▒	▒	▒

OFF = Disabled

ON = Enabled

Alarm 2 Activate on Voltage Phase Unbalance

■ = OFF □ = ON ▒ = Not Applicable

Select Switch	Setpoint Switch #							
Position	1	2	3	4	5	6	7	8
7	▒	▒	▒	▒	▒		▒	▒

OFF = Disabled

ON = Enabled

Alarm 2 Activate on Voltage Phase Reversal

■ = OFF □ = ON ▒ = Not Applicable

Select Switch	Setpoint Switch #							
Position	1	2	3	4	5	6	7	8
7	▒	▒	▒	▒	▒	▒	▒	▒

OFF = Disabled

ON = Enabled

Alarm 2 Trip Delay

■ = OFF □ = ON ▒ = Not Applicable

Select Switch	Setpoint Switch #							
Position	1	2	3	4	5	6	7	8
A	▒	▒	▒	▒	▒	▒	▒	▒

See Table 5.R

Alarm 2 Activate on Current Phase Loss

■ = OFF □ = ON ▒ = Not Applicable

Select Switch	Setpoint Switch #							
Position	1	2	3	4	5	6	7	8
7	▒	▒	▒	▒	▒	▒	▒	▒

OFF = Disabled

ON = Enabled

Alarm 2 Reset Delay

■ = OFF □ = ON ▒ = Not Applicable

Select Switch	Setpoint Switch #							
Position	1	2	3	4	5	6	7	8
A	▒	▒	▒	▒	▒	▒	▒	▒

See Table 5.S

Alarm 2 Enable/Disable

■ = OFF □ = ON ▒ = Not Applicable

Select Switch	Setpoint Switch #							
Position	1	2	3	4	5	6	7	8
A	▒	▒	▒	▒	▒	▒	▒	▒

OFF = Disabled

ON = Enabled

Alarm 2 Overvoltage Detection Level

■ = OFF □ = ON ▒ = Not Applicable

Select Switch	Setpoint Switch #							
Position	1	2	3	4	5	6	7	8
A	▒	▒	▒	▒	▒	▒	▒	▒
B	▒	▒	▒	▒	▒	▒	▒	▒

See Table 5.T

Alarm 2 Undervoltage Detection Level

■ = OFF □ = ON ■ = Not Applicable

Select Switch	Setpoint Switch #							
Position	1	2	3	4	5	6	7	8
B								

See Table 5.U

Alarm 2 Reset Threshold

■ = OFF □ = ON ■ = Not Applicable

Select Switch	Setpoint Switch #							
Position	1	2	3	4	5	6	7	8
C								

See Table 5.W

Alarm 2 Voltage Phase Unbalance Detection Level

■ = OFF □ = ON ■ = Not Applicable

Select Switch	Setpoint Switch #							
Position	1	2	3	4	5	6	7	8
B								

See Table 5.V

Optional I/O Setpoint Record Sheet

Discrete Input Setup

■ = OFF □ = ON ▒ = Not Applicable

Select Switch	Setpoint Switch #							
Position	1	2	3	4	5	6	7	8
5	▒	▒	▒	▒	▒	▒	▒	▒

OFF = Input is used as a Sync Pulse

ON = Input is used as an External Reset

Sync Pulse

■ = OFF □ = ON ▒ = Not Applicable

Select Switch	Setpoint Switch #							
Position	1	2	3	4	5	6	7	8
5	▒	▒	▒	▒	▒	▒	▒	▒

OFF = Sync Pulse is from discrete input

ON = Demand window is timed internally

Pulse Initiator/Load Shed

■ = OFF □ = ON ▒ = Not Applicable

Select Switch	Setpoint Switch #							
Position	1	2	3	4	5	6	7	8
D	▒	▒	▒	▒	▒	▒	▒	▒

OFF = Relay acts as pulse initiator

ON = Relay acts as load shed

Pulse Initiator Parameter

■ = OFF □ = ON ▒ = Not Applicable

Select Switch	Setpoint Switch #							
Position	1	2	3	4	5	6	7	8
D	▒	▒	▒	▒	▒	▒	▒	▒

See Table 5.X

Load Shed Range

■ = OFF □ = ON ▒ = Not Applicable

Select Switch	Setpoint Switch #							
Position	1	2	3	4	5	6	7	8
E	▒	▒	▒	▒	▒	▒	▒	▒
D	▒	▒	▒	▒	▒	▒	▒	▒

See Table 5.Y

Restore Load

■ = OFF □ = ON ▒ = Not Applicable

Select Switch	Setpoint Switch #							
Position	1	2	3	4	5	6	7	8
E	▒	▒	▒	▒	▒	▒	▒	▒
D	▒	▒	▒	▒	▒	▒	▒	▒

See Table 5.Y

Load Shed Parameter

■ = OFF □ = ON ▒ = Not Applicable

Select Switch	Setpoint Switch #							
Position	1	2	3	4	5	6	7	8
F					▒	▒	▒	▒

See Table 5.Z

Pulse Initiator Rate

■ = OFF □ = ON ▒ = Not Applicable

Select Switch	Setpoint Switch #							
Position	1	2	3	4	5	6	7	8
F	▒	▒	▒	▒				

See Table 5.AA