

SECTION 5: OPERATION

5-1 GENERAL

This section specifically describes the operation and functional use of the IQ Analyzer. It is divided into the following main categories:

- Display Mode (“Meter Menu”)
- Help Mode
- Programming Mode
- General Setup
- Inputs/Outputs
- Analysis Modes
- Communications
- Reset Mode

The practical use of and operation within each specific category will be discussed. In this section it is assumed that prior sections have been reviewed and that the operator has a basic understanding of the hardware. It is important that the operator have a good grasp of the functional use of the operator panel (Section 3). This will make movement within each category and between categories a simple task and quickly put the capabilities of the IQ Analyzer at the operator’s fingertips.

NOTICE

The key labels (definitions) for the F1-F4 Function Pushbuttons change as indicated on the display, depending upon which category is being viewed.

Detailed tables of measured parameters, accuracies and status information associated with any particular category are provided in this section. In addition to the information contained in this section on programming, Section 6 is devoted to actual programming steps and examples to help simplify the process.

5-2 DISPLAY MODE (“METER MENU”)

The IQ Analyzer monitors and displays a comprehensive list of metered parameters. Multiple parameters, such as the currents of phases A, B and C, are displayed simultaneously for thorough real time monitoring. Custom screens can be configured to view parameter groupings, such as volts, amperes and power factor (paragraph 5-2.3.1).

The “Meter Menu” provides easy access to the most commonly used metered parameters through its

combination of the display window, “Up and Down” pushbuttons and 12 Function LEDs (Figure 2-1). When in the Display Mode, the “Up and Down” pushbuttons permit viewing of screens for each of the following categories:

- | | |
|-----------------|---------------------|
| • Current | • Demand |
| • Voltage | • Power Factor |
| • Power (Watts) | • Frequency |
| • Power (Vars) | • % THD |
| • Power (VA) | • Distortion Factor |
| • Energy | • Custom |

Individual categories are visually presented in the display on one or more screens. Movement from one category to another is accomplished using the “Up” or “Down” pushbuttons. Holding either pushbutton depressed will scroll through the category screens to more quickly reach a particular category of the twelve available. The “Home” pushbutton permits rapid movement back and forth between the Current and Demand categories at the top of each column of LEDs.

When the IQ Analyzer is initially energized, the “Normal LED” will blink green, the “Current LED” indicator of the “Meter Menu” will be lit red, and the display will show phases A, B and C currents in amperes for the system being monitored. Individual screens are identified below the monitored parameters, which would be “AMPERES” for this particular screen. The very bottom of the screen defines the use of function pushbuttons F1-F4 for that particular screen (Figure 5-1). Note that the definitions of the function pushbuttons can change between screens.

The user friendly screens are self explanatory to minimize the amount of definition required by an operator. For example:

- Phase Currents Identified as - IA, IB and IC
- Neutral Current Identified as - IN
- Ground Current Identified as - IG
- **Average Current All Phases Identified as - I***

It will be noticed that any identification that is less than obvious, such as I* for average phase currents, is defined on the screen in which it is used (Figure 5-2).

NOTICE

Keep in mind that when an IQ Analyzer is initially powered up for use on a specific system, the displayed “Meter Menu” values may not be what is anticipated for that system. This is because the unit



Figure 5-1 Meter Menu Initial Current Screen



Figure 5-2 Second Meter Menu Current Screen

has not yet had necessary pieces of system information programmed into non-volatile memory.

5-2.1 DISPLAYED PARAMETERS

The IQ Analyzer displays the most comprehensive list of metered parameters in its class. A wide variety of real-time parameters and status parameters are quickly accessible via the front operator panel or through the communications port (Table 5.1).

The displayed information features:

- All information accessible via communications port
- Quality, true rms readings through 50th harmonic
- Accurate readings for non-sinusoidal wave forms with up to 3.0 crest factor
- Screens display auto ranging units, kilo units and mega units as needed

Table 5.1 Meter Menu Displayed Information

Display Type	Comments
Current	<ul style="list-style-type: none"> • Phase A, B, C, Average • Neutral • Ground (Separate ct inputs for each)
Voltage	<ul style="list-style-type: none"> • Phase A-B, B-C, C-A, Average • Phase A-N, B-N, C-N, Average • Neutral - Ground
Power	<ul style="list-style-type: none"> • System^① and Phase A, B, C • Real (watts) • Reactive (vars) • Apparent (VA)
Energy	<ul style="list-style-type: none"> • Forward, Reverse and Net • Real (kWh) • Reactive (kvar) • Apparent (kVAh - Net only)
Frequency	<ul style="list-style-type: none"> • Hz • Time • Date
Demand	<ul style="list-style-type: none"> • System Current (A) • System Real Power (kW) • System Reactive Power (kvar) • System Apparent Power (kVA)
Power Factor	<ul style="list-style-type: none"> • System and Phase A, B, C • Displacement^② • Apparent^③
% THD Currents	<ul style="list-style-type: none"> • Phase A, B, C • Neutral
% THD Voltages	<ul style="list-style-type: none"> • Phase A-B, B-C, C-A • Phase A-N, B-N, C-N
Distortion Factor	<ul style="list-style-type: none"> • K-Factor^④ (of Event) • CBEMA Derating^⑤ Factor (THDF) • Crest Factor^⑥
Custom	<ul style="list-style-type: none"> • Discrete Input and Output Status • Analog Input Reading • User can program two screens to show any combination of 7 Meter Menu parameters per screen

- ① Line to neutral values do not apply for 3-wire system, use system values.
- ② Fundamental watts to VA.
- ③ Total rms watts to VA.
- ④ K-Factor: A derating factor which is essentially the sum of the squares of individual harmonic currents times the squares of their harmonic number (i.e., multiples of fundamental). One for each current is displayed with largest recorded in Event metered data.
- ⑤ CBEMA Factor: A transformer harmonic derating factor defined as a pure sine waves crest factor (1.414) divided by the measured crest factor.
- ⑥ Crest Factor: The ratio of peak current to rms current.

- 9 digit energy readings
- Simultaneously displays multiple parameters
- Custom screen programming

5-2.2 DISPLAYED SIGN CONVENTIONS

As a factory default, lagging vars and power factor are represented as negative values at the load. This is consistent with $P = VI$. The alternative is a power engineering convention which uses $P = VI^*$ such that consumption of power is positive. In this way a motor conveniently consumes positive watts and positive vars. Changing this setting has no effect upon the unsigned “LEADING KVAR-HR” and “LAGGING KVAR-HR” energy readings. The signed “NET KVAR-HR” energy will, however, begin counting in the opposite direction.

The desired sign convention (+ or -) for vars and power factor is programmed using Display Options within Display Manager of the Programming Mode. Refer to paragraph 5-5.8 for specific selection information.

A negative sign convention corresponds to:

- Inductive Load = negative var and power factor values (lagging power factor)
- Capacitive Load = positive var and power factor values (leading power factor)

A positive sign convention corresponds to:

- Inductive Load = positive var and power factor values (lagging power factor)
- Capacitive Load = negative var and power factor values (leading power factor)

As mentioned previously, power engineers typically use the positive sign convention as a standard. The negative sign convention is mathematically correct. The sign convention selected determines whether the leading or lagging power factor is positive or negative in terms of minimum and maximum values. Figure 5-3 illustrates two possibilities. Refer to Figures 5-4 and 5-5 for the specifics associated with both the Mathematical and the Power Engineer’s sign conventions.

The following typical examples are offered based on the assumption that the unit is using the Mathematical sign convention:

- Induction Motor Loads (Figures 5-4 and 5-6): Typically when monitoring induction motor loads the power flow is in Quadrant 4. The watts are positive and the power factor is lagging. By definition, the power factor and vars are negative.

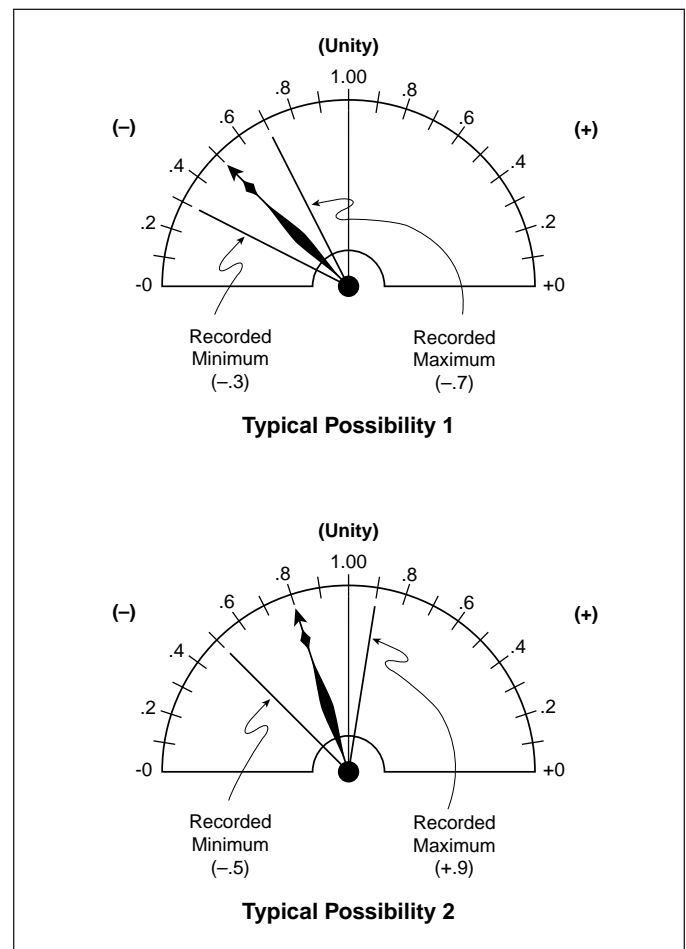

Figure 5-3 Typical Power Factor Minimum/Maximum Possibilities

- Power Factor Correction Capacitors (Figure 5-4): When monitoring a load that also has power factor correction capacitors and/or leading power factor synchronous motors so that the new load is capacitive, the power flow is in Quadrant 1.
- Power Distribution (Figures 5-4 and 5-7): Three conditions are typically encountered when monitoring power distribution systems as follows:
 1. Circuit breakers A and B are closed and C is open. Power flow is in Quadrant 4. The power factor and vars are negative.
 2. Circuit breakers A and C are closed and B is open. Power flow for breakers A and C is in Quadrant 4. The power factor and vars are negative.

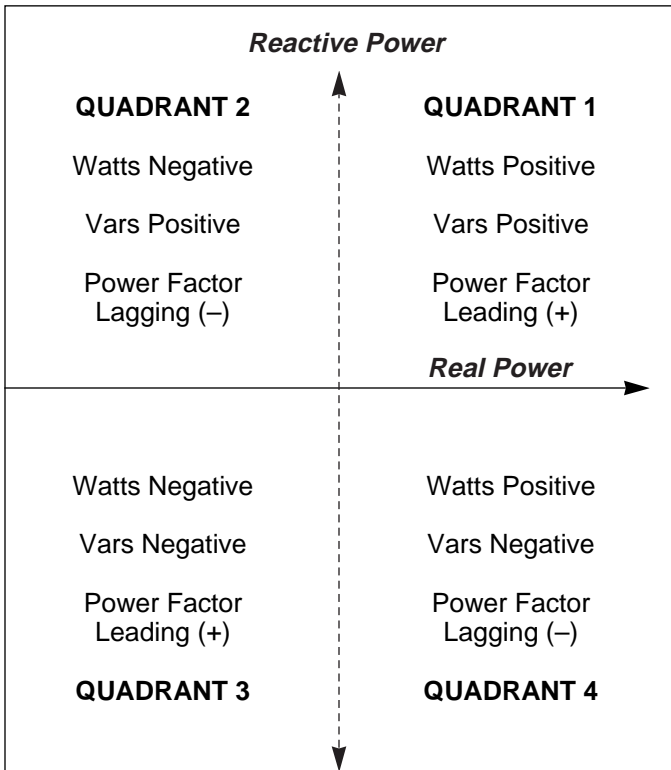

Figure 5-4 Power Quadrants, Mathematical

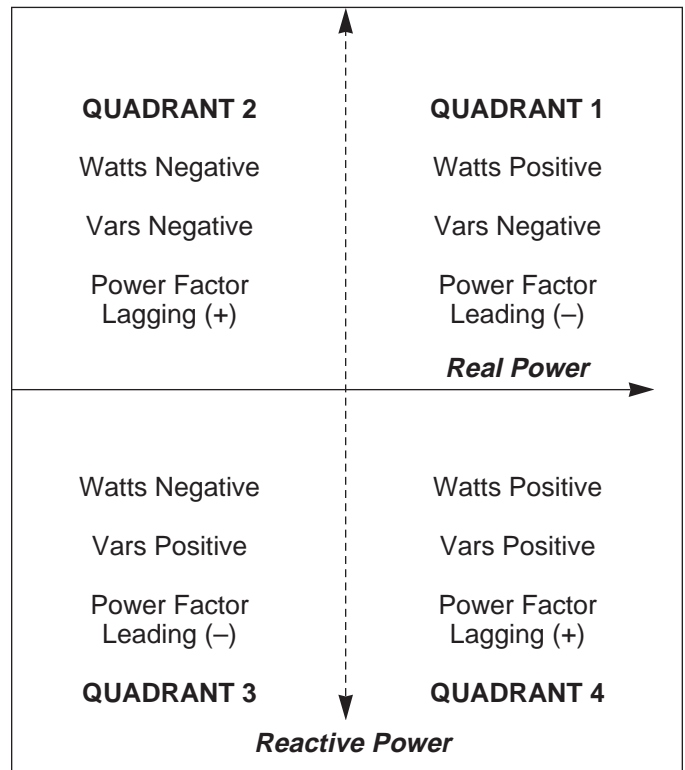

Figure 5-5 Power Quadrants, Power Engineers

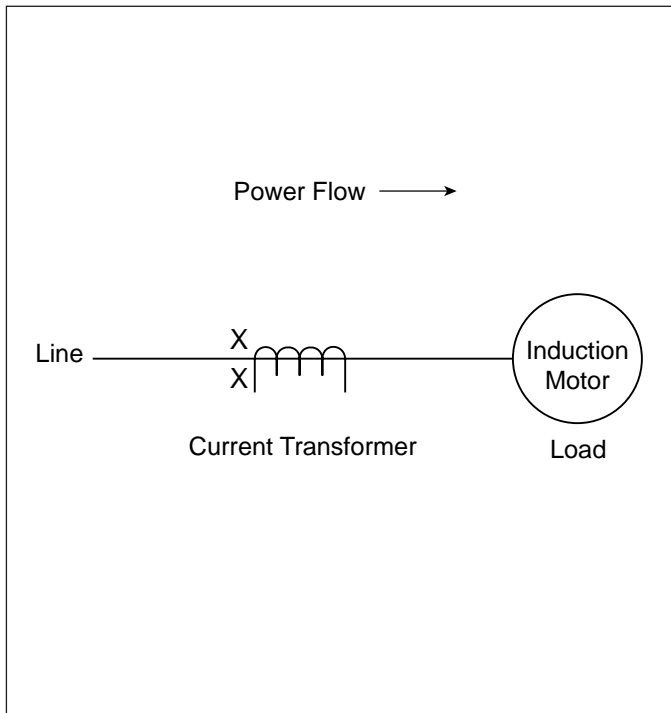

Figure 5-6 Induction Motor Load

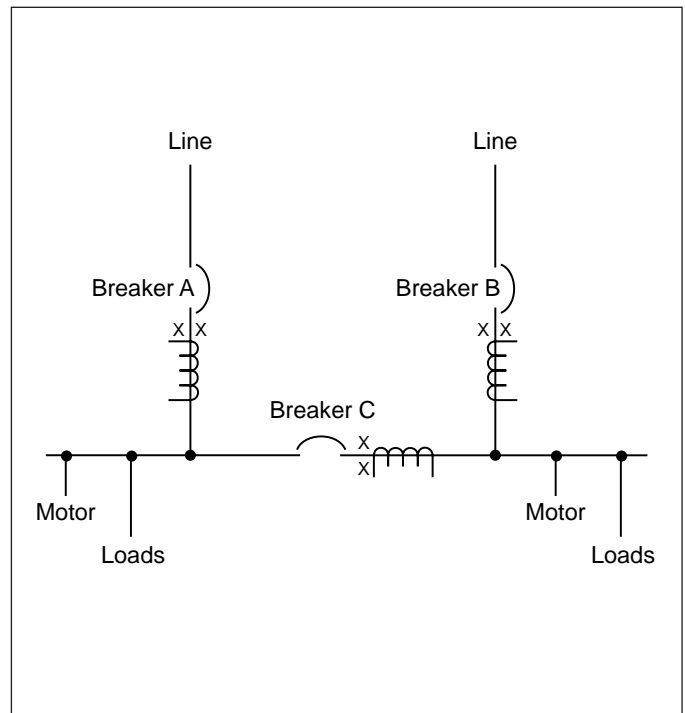

Figure 5-7 Power Distribution

3. Circuit breakers B and C are closed and A is open. The power flow for breaker B is in Quadrant 4 and the metering condition is the same as conditions 1 and 2. However, the power flow for breaker C is reversed and is in Quadrant 2.

5-2.3 DISPLAY MANAGER

The programmable Display Manager is comprised of three convenience functions:

- Meter Menu Return Time
- Custom Screens
- Screen Saver
- Display Options

5-2.3.1 METER MENU RETURN TIME

The IQ Analyzer is set at the factory with a 15 minute default time for returning the display to the Main Meter Menu, if no activity is detected by the IQ Analyzer during the 15 minute time period. A programmed return to the Main Meter Menu applies to the Program Mode, Reset Mode, Help Mode or analysis screens. When a return to the Main Meter Menu takes place, a screen saver is automatically activated. Meter Menu Return Time is programmable for 0 to 15 minutes with zero meaning no return.

5-2.3.2 CUSTOM SCREENS

Custom Screens can be configured to view a grouping of selected parameters for convenience or to concurrently observe their relationships as conditions change. Up to fourteen different parameters can be programmed from sixty different parameter possibilities, plus a “Default” selection (Table 5.2). Selecting “Default” automatically programs fourteen pre-selected parameters. For more detailed information on Custom Screens or a comprehensive list of all possible parameter selection, refer to Appendix A, Startup Settings Sheet #8.

5-2.3.3 SCREEN SAVER

The IQ Analyzer has a screen saving feature which blanks or dims the display after a pre-selected time period. The Time period will be the same as that programmed for the Meter Menu Return Time. Whether the display goes blank or dim is the user’s choice during programming of Display Manager. In any case, pressing any pushbutton restores the display to full brightness.

5-2.3.4 DISPLAY OPTIONS

There are four programmable options available (Table 5.2). The option definitions provided in Table 5.3 are also available by using the “Help” pushbutton when viewing the Display Options screen (Figure 5-8).

Example: To disable the local alarm displays, use the F1 pushbutton (right arrow -->) and the F2 pushbutton (Set) to move to and set Bit1 to 1 as shown in Figure 5-8.

5-3 HELP MODE

The IQ Analyzer supports Help screens providing useful information on the device’s operation, programming and troubleshooting. Information displayed is intended as basic reminders on how to move within a specific mode of operation and/or between different modes. The Help feature is not intended to be a substitute for the information provided in this manual. A basic understanding of the IQ Analyzer gained by reviewing the contents of this manual will optimize the usefulness of the Help feature.

Table 5.2 Custom Screen Parameters

Category	Available Parameters
Current	I _a , I _b , I _c , I _n , I _g
Voltage	V _{an} , V _{bn} , V _{cn} , V _{ab} , V _{bc} , V _{ca} , V _{ng} , LL avg, LN avg
Frequency	System
Power	Watts, vars, VA (Phase a, b, c, and system)
Energy	Forward/reverse/net Wh, lead/lag/net varh, VAh
Demand	Current, watts, vars, VA
PF displacement	Phases a, b, c, and system
PF apparent	Phases a, b, c, and system
% THD	I _a , I _b , I _c , I _n , V _{an} , V _{bn} , V _{cn} , V _{ab} , V _{bc} , V _{ca}
Distortion Factor	THDF (CBEMA), Crest Factor, K-Factor
Blank Line	
Default 14	lavg, I _g , VLL avg, System watts, vars and VA, Net Wh, % THD (I _a , I _b , I _c , I _n , V _{ab} , V _{bc} , V _{ca})

When the Help Pushbutton is pressed, the first of two Help Menu screens appears highlighting five Help categories (Figure 5-9). A Help category can be selected from that screen, or the F4 Pushbutton (PGDN) can be used to view the second Help Menu screen. Three additional Help categories are highlighted on the second screen (Figure 5-10).

Once a Help Category is selected via F1 (SEL), additional screens provide helpful assistance pertaining to the specific Help Category selected. For example, if the Help Category selected is “FACEPLATE OPERATION,” two main screens of specific selections are provided (Figures 5-11 and 5-12). Each selection is supported by additional screens of explanatory information intended to review the use and/or function of every Pushbutton and LED on the faceplate of an IQ Analyzer.

To exit the Help Mode, press and release the “Help” pushbutton. For additional information about pushbuttons, refer to paragraphs 3-3 and 3-4.

5-4 PROGRAMMING MODE

The IQ Analyzer is fully programmable from the device's faceplate or through a communications port. Programming is password protected whether the programming function is being performed directly from the faceplate or through a remotely located computer. A view only password (00000) is provided to permit viewing but not changing of previously programmed setpoints.

Taking full advantage of the capabilities of IQ Analyzer is heavily dependent on the programming function. Therefore, programming proficiency is highly recommended. Detailed programming information associated with specific features is presented in this section with the individual features, such as programming associated with general setup, trends, events, harmonics, and demands. This information will be helpful, and in some instances required, when the actual programming takes place. Any operator associated with programming will quickly discover that programming an IQ Analyzer is just a matter of simple, repetitive steps.

Table 5.3 Display Options ^①

Bit	Factory Default	Option 2
0	0 = Kilo units (e.g. Kilowatt-Hr)	1 = Mega units (e.g. Megawatt-Hr)
1	0 = Normal Operation	1 = Disable event/alarm screens. Useful when discrete inputs trigger an event either manually or periodically
2	0 = Normal blanking of line-to-neutral parameters in a 3-wire delta configuration (otherwise readings for V_{AN} , V_{BN} , and V_{CN} might be confusing to user without a neutral)	1 = Show all parameters
3 ^{②③}	0 = Mathematical power convention in which Power = VI. Lagging vars and power factor are negative for a load (positive for a generator)	1 = Power Engineering convention in which Power = VI*. Lagging vars and power factor are positive for a load (positive for a generator)
4 - 7	Undefined	Undefined

① Bit0 is rightmost and Bit7 is leftmost in eight digit display.

② Refer to paragraph 5-2.2 for more details on displayed sign conventions.

③ The sign convention can also be set by programming it in Power/Energy Options in the General Setup menu.



Figure 5-8 Display Options Screen

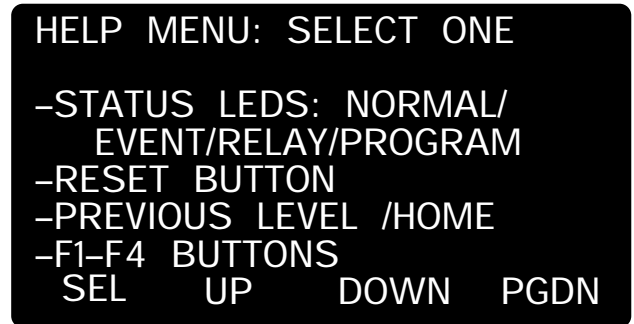

Figure 5-11 Faceplate Operation First Screen Selections

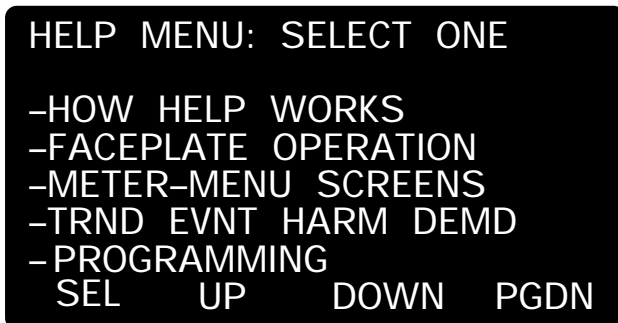

Figure 5-9 First Help Menu

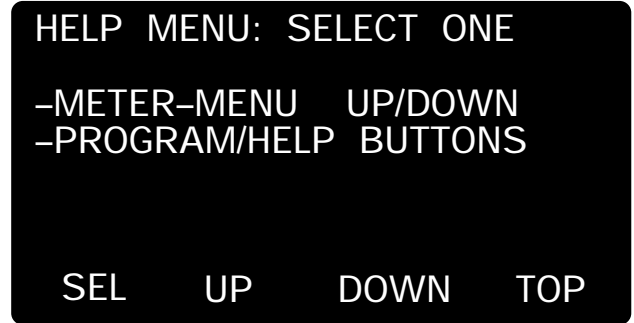

Figure 5-12 Faceplate Operation Second Screen Selections

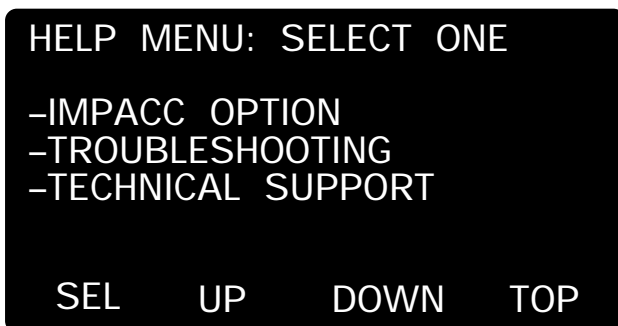

Figure 5-10 Second Help Menu

Because of the importance placed on the programming function, Section 6 is dedicated to general programming activities. Three main topics are addressed in Section 6 to improve programming proficiency:

- Common Programming Procedures
- Programming Example
- Programming Categories

5-5 GENERAL SETUP

Performing the steps associated with the general setup of the IQ Analyzer is one of the first activities performed once the IQ Analyzer is properly installed and ready to be utilized. It is recommended that the General Setup Screens Tree (Figure 6-4), the Startup Settings Sheet #1 in Appendix A, and the IQ Analyzer's specifications (Table 2.1) be reviewed first. In addition, Quick Start Metering information is provided in paragraph 4-5 for those users initially interested in having the IQ Analyzer perform only basic metering functions quickly.

5-5.1 SYSTEM TYPE

The IQ Analyzer supports four configurations:

- Three-phase, four-wire (wye)
- Three-phase, three-wire (delta)
- Single-phase, two-wire
- Single-phase, three wire

The wye and delta configurations have a phase rotation of ABC or CBA. If the rotation setting does not agree

with the incoming voltage, “**REVERSE SEQUENCE, MISWIRING LIKELY**” is displayed.

As a default, the delta configuration disables the display of line-to-neutral voltages. In any case, the neutral terminal on the power module must be connected. In a wye configuration, merely connect the four wires. Similarly, in a single-phase configuration connect the neutral wire to the neutral terminal. In a delta system, however, connect the neutral terminal to the chassis ground. Refer to Section 4 for wiring diagram assistance.

NOTICE

It is not uncommon to have misplaced phases throughout a factory such that the actual rotation is the opposite of how the wires are labeled. If a reverse sequence alarm appears, check the phasing through the use of the Harmonic Analysis Mode.

Check the phasing by using the analysis feature as follows:

1. Press the F3 (HARM) pushbutton
2. Capture an event with the F4 (NEW) pushbutton
3. Observe phase angle of the fundamental V_{AB} and V_{CA}

An ABC rotation will have a phase angle of -120 degrees for V_{AB} fundamental. Regardless of the configuration, the voltage between the neutral terminal and ground terminal is measured such that leaving either terminal disconnected may cause the alarm, “**HIGH NEUTRAL VOLTAGE, MISWIRING LIKELY.**” **Note that acknowledging an alarm screen inhibits alarms again until the screen saver becomes active. This allows the use of the device in situations with persistent alarms.**

5-5.2 FREQUENCY

The IQ Analyzer has four default frequencies:

- 25Hz
- 40Hz
- 50Hz
- 60Hz

Upon power up in the absence of a phase-A voltage in which to frequency lock, the IQ Analyzer samples according to the set default. This setting is also used for comparison when programming a trigger on frequency deviation. The full scale value is the system frequency setting.

5-5.3 INCOMING LINE-TO-LINE VOLTAGE

Line-to-line voltages of up to 600 volts rms can be wired directly into the Analyzer without the need for potential transformers (PTs). For this reason, the analog outputs need to define full scale based on the incoming line-to-line voltage. That is, a full scale analog output is defined by the rated current and voltage. However, this setting has no effect on the use of the pulse-initiator relays. The incoming line-to-line voltage may be set between 100 and 600 volts.

5-5.4 PT PRIMARY LINE-TO-LINE RATING

When no potential transformers (PTs) are used, the PT ratio is 1:1 (i.e. 120:120). For example, a 480 volt system wired directly has a PT primary line-to-line rating of 120 with an incoming line-to-line voltage of 480 volts. This setting in conjunction with the incoming line-to-line voltage and CT primary rating define the full scale range for analog outputs. The PT primary rating may be set from 120 volts to 500 kilovolts.

5-5.5 CT PRIMARY RATING

The rating of the current transformers (CTs) is relative to 5 amperes. Normally a system rated at 2000 amperes per phase would have a CT ratio of 2000:5. However, **since the IQ Analyzer has an 8x overranging capability, as much as 40 amperes can run continuously** through the CT inputs. If only a small fraction of the rated current is used, one can increase the resolution 8 times by making the ratio relative to 40 amperes in lieu of 5 amperes. For example, the same 2000 ampere system may be specified as 2000:40, which is 250:5. This setting along with the PT primary rating and incoming line-to-line voltage define the full scale range for analog outputs. The CT primary rating may be set between 5 and 10000 amperes and applies to I_a , I_b , I_c , and I_n . The full scale value for currents is the CT primary setting.

5-5.6 GROUND CT PRIMARY RATING

This is the CT primary rating of the ground current input. Alternatively, a zero-sequence CT may be substituted, with the residual of I_a , I_b , I_c and I_n run through the input, or leave the input terminals disconnected. As with the other current inputs, **the IQ Analyzer has 8x overranging, such that 40 amperes can run continuously** through the ground current input. Typically, a lower CT ratio is selected for the ground CT primary rating than for other current inputs. The ground

CT primary rating may be set between 5 and 10000 amperes. Ig has a full scale value equal to the ground CT primary setting

5-5.7 PROGRAMMING OPTIONS

For revenue metering applications, the IQ Analyzer has extended PROGRAMMING OPTIONS, previously labeled PROGRAM VIA IMPACC. In this way, the IQ Analyzer simultaneously serves the needs of utilities and industrial users. The factory default is to enable changes at the faceplate and via IMPACC. However, for revenue metering there are two additions – INPUT3 KEY ONLY and INPUT3 KEY & IMPACC, which disabled selected settings with a contact closure on Discrete Input#3 (Figure 5-13).



Figure 5-13 Download Program Screen

The disabled changes to settings are the General Setup, Discrete Inputs, Pulse Initiator Relays, and Demand. Still, all functions are fully functional. These include: relays for load shedding, relays tied to events or IMPACC. Similarly, changes to analog I/O, event triggers, and display options remain fully enabled.

Also protected are resets of peak demands and energies. These include peak kW, kvar, kVA and kWh, Kvarh, and kVAh.

Operation of FACEPLATE ONLY

With this selection, all settings are changed via the faceplate. Reset of peak demands is possible at the faceplate or via IMPACC; however, reset of energy is only possible via IMPACC.

Operation of FACEPLATE & IMPACC

With this default selection, all settings are changed at the faceplate or via IMPACC. Reset of peak demands is possible at the faceplate or via IMPACC; however, reset of energy is only possible via IMPACC. This selection provides the most open access.

Operation of INPUT3 KEY ONLY

With this selection, Discrete Input#3 must remain open to change the protected settings via the faceplate or any settings via IMPACC. The peak demands and energies are similarly protected. This option is most useful when those responsible for energy billing are not the same as those who use the IMPACC system. This selection provides the most restricted access.

Operation of INPUT3 KEY & IMPACC

With this selection, Discrete Input#3 must remain open to change the protected settings or reset peak demands and energies at the faceplate. IMPACC setting changes and resets are enabled. This option is most useful when those responsible for energy billing are also responsible for an IMPACC system that is restricted to authorized personnel.

5-5.8 POWER/ENERGY OPTIONS

KILO or MEGA energy units (kilowatt-hr or megawatt-hr) can be selected for display during the general setup procedure. In addition, the Power Convention can be selected, permitting the user to choose between the mathematical and the power engineering conventions. As a factory default, the IQ Analyzer uses the mathematical convention in which lagging vars and power factor are represented as negative values for a load (positive for a generator).

Programming both KILO or MEGA energy units and the Power Convention can also be accomplished from the Display Manager under Display Options. For more details on Display Options, refer to Table 5.3. For a discussion of Power Conventions, refer to paragraph 5-2.2.

5-5.9 DATE AND TIME

If an IMPACC system running Series III software (paragraph 5-8) is being utilized, no entry is necessary as the time and date will be downloaded upon startup and synchronized once a minute. Otherwise, enter the date and time by selecting the desired item from the menu, modifying the value, and entering (Figure 5-14).

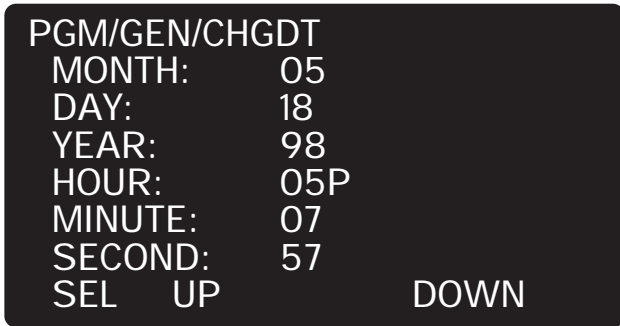

Figure 5-14 Change Date and Time Screen

After the hour is entered, the F3 pushbutton is identified as AM/PM. Use this pushbutton to make the AM or PM selection and enter.

5-5.10 CHANGE PASSWORD

Both the Program Mode and Reset Mode are password protected. The correct password must be entered to proceed into these modes. The IQ Analyzer is supplied from the factory with default passwords of **10000** or **44444**. These default passwords can be used on initial powerup and until a new password is programmed by the user. For details on passwords and password entry, refer to paragraph 6-2.2.

5-6 INPUTS/OUTPUTS

The IQ Analyzer provides extensive input/output capabilities. One analog and three digital inputs are provided to interface with sensors and transducers. Three analog output and four relay contacts are furnished to share data with PLCs and control systems and to actuate alarms and control relays. Remote monitoring, control and programming is possible through the communications option.

5-6.1 DISCRETE CONTACT INPUTS

Three programmable dry contact discrete inputs have multiple functions.

- Each can trigger an event to capture metered, harmonic, and waveform data.
- Each can reset peak demands, min/max values, one relay, or as many as seven locked event triggers.
- Discrete input #1 also functions as the sync demand

input, which is then tied to the sync demand pulse from the electric utility.

Even when set as a reset input or sync, each discrete input can trigger an event. As a reset input, it can reset the following:

- Peak current and power demands
- All min/max values
- Locked triggers
- Individual relays (with manual resets)

5-6.2 ANALOG INPUT

One analog input is provided and can be configured as 0 to 20 or 4 to 20 mA. It is displayed as a percentage, and provides an interface with gas flow meters, temperature transducers or other analog devices.

The analog input can be configured to accept different inputs (Figures 5-15 and 5-16). Also refer to Figures 4-31 and 4-32 for specific analog input wiring diagrams.



WARNING

CONNECT THE SHIELD PATH TO A SOLID EARTH GROUND AT THE DEVICE ONLY. IF THE SHIELDS ARE GROUNDED AT A NUMBER OF POINTS, A GROUND LOOP MAY BE CREATED CAUSING HAZARDOUS VOLTAGES TO BE PRESENT ON THE DEVICE'S CHASSIS. FAILURE TO COMPLY WITH THIS WARNING COULD RESULT IN BODILY INJURY OR DEATH.

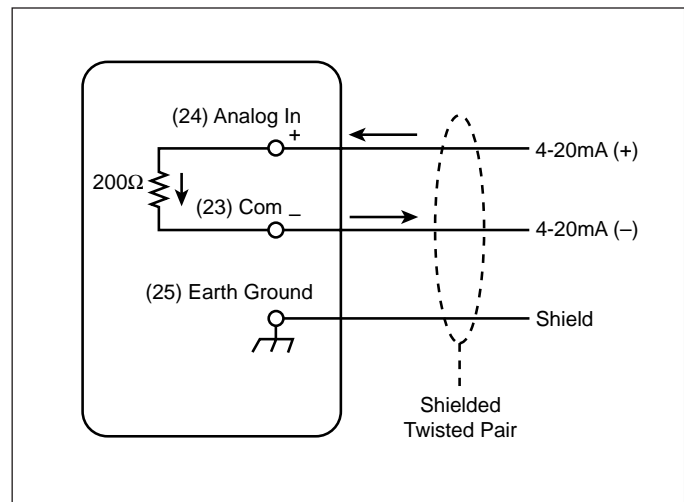

Figure 5-15 Connections for 4-20 or 0-20mA Input Signal

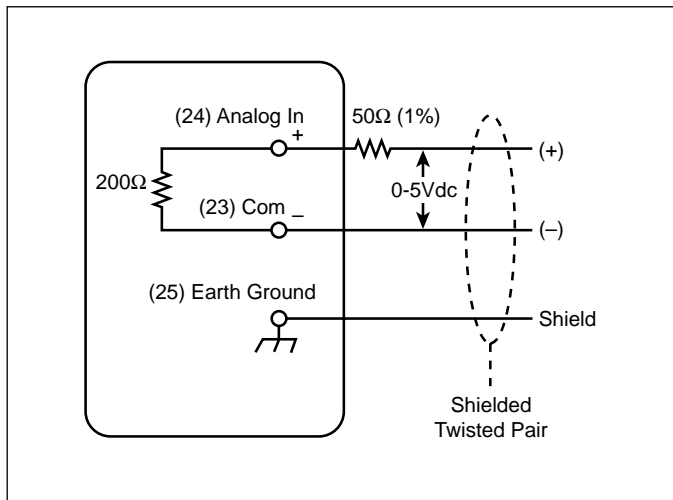

Figure 5-16 Connections for 0-5Vdc Input Signal

Table 5.4 Analog Output Parameters

Category	Available Parameters
Current	$I_a, I_b, I_c, I_n, I_g, I_{avg}$
Voltages	$V_{an}, V_{bn}, V_{cn}, V_{ab}, V_{bc}, V_{ca}, V_{ng}$
Watts	Phases a, b, c, and system
Vars	Phases a, b, c, and system
VA	Phases a, b, c, and system
% THD Current	I_a, I_b, I_c, I_n
% THD Voltage	$V_{an}, V_{bn}, V_{cn}, V_{ab}, V_{bc}, V_{ca}$
Frequency	V_{an}
Power Factor	System Displacement, System Apparent

5-6.3 ANALOG OUTPUTS

Three analog outputs are provided. The output signal is the analog current value out, which is proportional to a preprogrammed value in the IQ Analyzer. The choices are:

- 0-20mA**
- 4-20mA**

Analog outputs can be programmed to reflect the parameters in Table 5.4 (currents, voltages, powers, %THDs, frequency, and power factors).

Refer to Analog Output Settings Sheet #3 in Appendix A for all the specific programmable parameters possibilities.

After the output is programmed to represent a specific parameter, set the range to either 0 to 20 or 4 to 20mA and the full scale output to 100% or 200%. For example, a 200% selection means that at 20mA, the selected parameter is twice its full scale value. Frequency is an exception in that 100% is 100Hz, so the output would be 20mA at 100Hz.

For signed power selections, there is a setting for what output represents zero watts or vars as follows:

5-6.3.1 RANGE

Selections are either 0-20mA or 4-20mA. The analogous operation is that of an analog meter whose largest outputs pegs at 20mA and whose smallest output pegs at either 0mA or 4mA, depending upon selection.

5-6.3.2 ZERO SCALE / MID-SCALE POSITION

This selection positions the value of zero. For Zero Scale 0mA or 4mA represents zero; this is always true for voltage, current, frequency and %THD. For watts and vars there is the option for zero to be Mid-Scale; zero being either 10mA or 12mA in the middle of the range 0 to 20mA or 4 to 20mA range.

The zero position setting is independent of range such that for a 4 to 20mA output with a full scale of 200% and Mid-Scale position the output is as follows: a power of minus two times full scale is 4mA; minus full scale is 8mA; zero is 12mA full scale is 16mA; and two times full scale is 20mA. Power is always in the Mid-Scale position.

The best way to imagine the zero scale is to think about analog meters. There are three possible types. The first reads from a zero position to a positive maximum value. The second reads from zero position to a negative maximum value. The third reads both ways, positive and negative, from a mid-scale zero position.

- Zero Scale +: minimum = 0; maximum = positive value
- Zero Scale -: minimum = 0; maximum = negative value
- Mid-Scale: minimum = negative value; mid-range = 0; maximum = positive value

Analog outputs are configured as shown in Figure 5-17. Refer to Figure 4-30 for specific analog output wiring diagram.

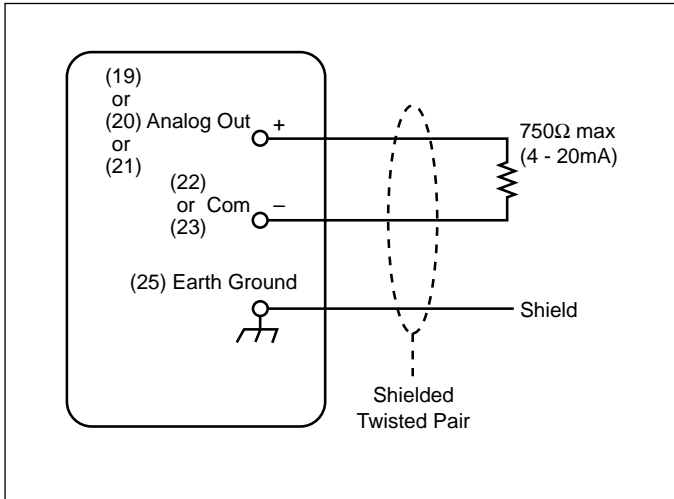

Figure 5-17 Analog Output Connections 4-20 or 0-20mA

5-6.3.3 FULL SCALE

This determines what value of analog current the preprogrammed maximum value will cause. The choices are:

- 100% = 20mA**
- 200% = 20mA**

The full scale output varies according to the selection (Table 5.5). The goal of the selection is to make 20mA represent a rated measurement (100%) or twice a rated measurement (200%). As discussed in earlier material, the full scale value for currents is the CT primary setting except for the ground current (I_g). I_g has a full scale value equal to the ground CT primary setting. Again, frequency is an exception in that its full scale value at 20mA is 200Hz.

For line-to-line voltages, the full scale value is the product of the incoming line-to-line voltage divided by 120 and PT primary setting. For line-to-neutral voltages, however, the full scale value is that of the line-to-line voltages divided by the square-root of 3.

The full scale value for system powers is three times the line-to-neutral voltage rating times the current rating. In other words, the full scale value of a per-phase watts is the product of the full scale line-to-neutral voltage and full scale current.

For %THD the full scale value is 100% or 200% of the selected item's fundamental frequency.

5-6.3.4 POSSIBLE COMBINATIONS FOR EACH ANALOG OUTPUT

Refer to Table 5.5

Table 5.5 Analog Output Combinations

Measured Attribute	Settings for Zero Position and Full Scale	Minimum Output (0 or 4mA)	Mid-Scale Output (10 or 12mA)	Maximum Output (20mA)	Equations (Settings shown in all capitals, see 5-5.3 to 5-5.6)
Frequency of Van (last time it was > 30V)	zero scale	0 Hz	50 Hz	100 Hz	
%THD	100%, zero scale	0%	50%	100%	
%THD zero scale	200%	0%	100%	200%	
Current zero scale	100%,	0 A	I _{rating} /2	I _{rating}	I _{rating} = CT PRIMARY RATING or GCT PRIMARY RATING
Current zero scale	200%,	0 A	I _{rating}	2*I _{rating}	
Voltage line-to-line	100%, zero scale	0 V	VLL _{rating} /2	VLL _{rating}	VLL _{rating} = PRIMARY RATING * INCOMING VLL / 120

Table 5.5 Analog Output Combinations (continued)

Measured Attribute	Settings for Zero Position and Full Scale	Minimum Output (0 or 4mA)	Mid-Scale Output (10 or 12mA)	Maximum Output (20mA)	Equations (Settings shown in all capitals, see 5-5.3 to 5-5.6)
Voltage line-to-line	200% zero scale	0 V	VLLrating	2*VLLrating	
Voltage line-to-neutral	100% zero scale	0 V	VLNrating/2	VLNrating	$VLNrating = VLLrating / \sqrt{3}$
Voltage line-to-neutral	200% zero scale	0 V	VLNrating	2*VLNrating	
Per-Phase Pwr (applies to non-delta systems)	100% zero scale	0 Watts 0 vars 0 VA	LinePwrRating/2	LinePwrRating	$LinePwrRating = VLNrating * Irating$
Per-Phase Pwr (applies to non-delta systems)	200% zero scale	0 Watts 0 vars 0 VA	LinePwrRating	2 times the LinePwrRating	
Per-Phase Pwr (applies to non-delta systems)	100% mid-scale	Negative LinePwrRating	0 Watts 0 vars	LinePwrRating	
Per-Phase Pwr (applies to non-delta systems)	200% mid-scale	2*Negative LinePwrRating	0 Watts 0 vars	2 times the LinePwrRating	
System Power	100% zero scale	0 Watts 0 vars 0 VA	SysPwr Rating/2	SysPwrRating	$SysPwrRating = 3 * VLNrating * Irating = (3 * LinePwrRating)$
System Power	200% zero scale	0 Watts 0 vars 0 VA	SysPwrRating	2 times the SysPwrRating	
System Power	100% mid-scale	Negative SysPwrRating	0 Watts 0 vars	SysPwrRating	
System Power	200% mid-scale	2*Negative SysPwrRating	0 Watts 0 vars	2 times the SysPwrRating	
System Power Factor (displacement or apparent)	100% mid-scale	Approaches Negative 0	Unity	Approaches+0	Sign conversion matches that of vars. The user may select lagging vars to be represented as positive or negative (see 5-2.2)



WARNING

CONNECT THE SHIELD PATH TO A SOLID EARTH GROUND AT THE DEVICE ONLY. IF THE SHIELDS ARE GROUNDED AT A NUMBER OF POINTS, A GROUND LOOP MAY BE CREATED CAUSING HAZARDOUS VOLTAGES TO BE PRESENT ON THE

DEVICE'S CHASSIS. FAILURE TO COMPLY WITH THIS WARNING COULD RESULT IN BODILY INJURY OR DEATH.

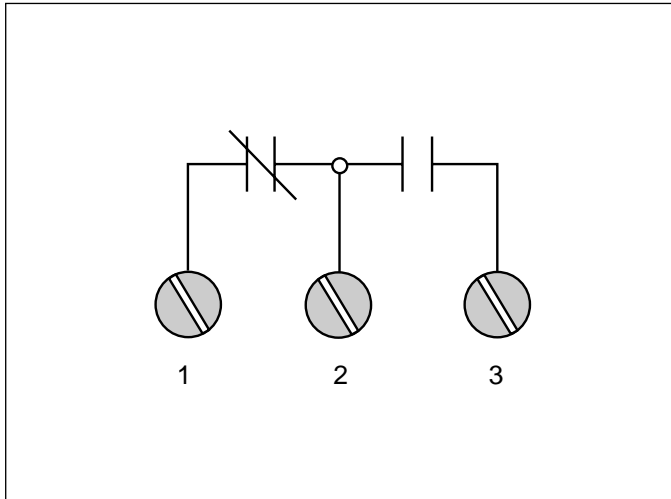

Fig. 5-18 Relay Contact with IQ Analyzer De-energized

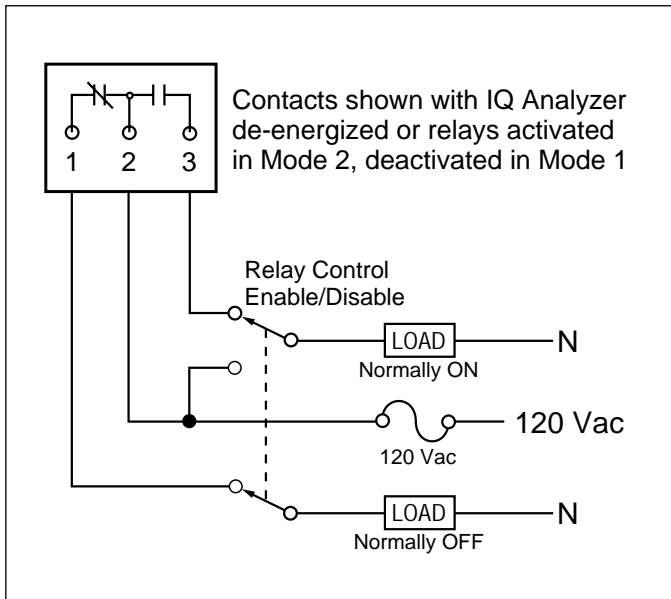

Figure 5-19 Typical Relay Output Connections

5-6.4 RELAY OUTPUT CONTACTS

Four Form-C (NO/NC) relay contacts are available (Figure 5-18). Because the relays have both normally open and normally closed contacts, the opposite polarity wiring to the opposite terminal can be chosen. The relays can be independently programmed to (Table 5.6):

Table 5.6 Typical Relay Application Possibilities

Relay Application	Relay Mode	Wired Terminals
Undervoltage, open upon alarm	2	2, 3
Undervoltage, close upon alarm	2	1, 2
Overcurrent, open upon alarm	1	1, 2
Overcurrent, close upon alarm (shunt trip)	1	2, 3
Load shed, open upon alarm, delay power up	2	2, 3
Load shed, open upon alarm	1	1, 2
Low power factor, close to add capacitance	1	2, 3
Reverse sequence, close upon alarm	1	2, 3
Reverse sequence, open upon alarm	1	1, 2
Pulse-Initiator	Either	Either pair
Alarm only when powered	1	Either pair
Alarm also when not powered	2	Either pair

- Be disabled
- Shed a load upon excessive demand
- Act as a pulse initiator
- Indicate a reverse voltage sequence
- Activate upon an event trigger
- Activate upon IMPACC command

Some of these options allow for either a manual reset (via “Reset” pushbutton or discrete input) or auto reset following a specified delay time of zero to 60 seconds.

Each relay output provides three terminals, normally closed, normally open and common. Figure 5-19 shows typical relay output connections.

5-6.4.1 LOAD SHEDDING

The load can be shed upon demand amps, demand watts, demand reverse watts, demand vars capacitive load, demand vars inductive load, or demand VA. Each load shedding selection has a threshold as if it were a trigger threshold. The relay can only change state on demand window boundaries. For example, with a 15-minute fixed window, the relay can only change state

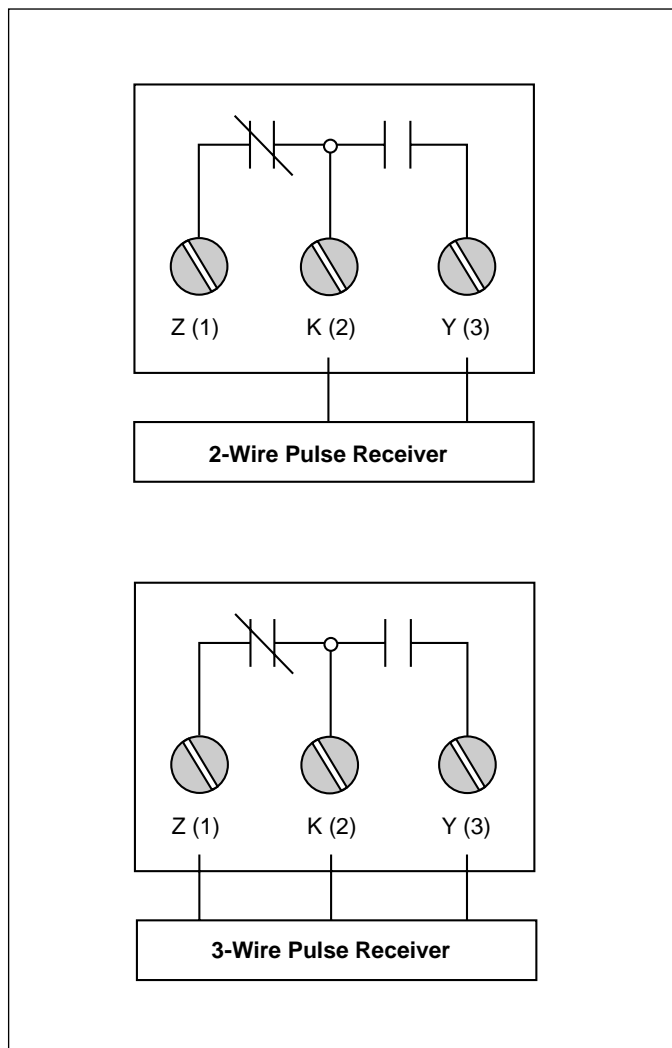

Figure 5-20 Pulse Output Connections

every 15 minutes. For details of demand operation see paragraph 5-7.4

5-6.4.2 PULSE INITIATOR AND INITIATOR SCALE

The relay can serve as a pulse initiator for all energies, whether forward, reverse, real, reactive, or apparent. Upon entering a selection for the pulse initiator, the IQ Analyzer requests a pulse initiator scale factor, which is an integer between 1 and 255. A setting of 1 would cause the relay to change state each $0.6 \text{ (Wh, varh, or VAh)} \cdot \text{PT primary rating} \cdot \text{CT primary rating}$. If the current is at the CT primary rating, and the scale factor is 10, the relay changes state every 12 seconds.

NOTICE

Using the pulse initiator with a scale factor of 1 at rated power continuously will wear out the relay within several months. Setting the scale to 100, for example, would extend the relay life by a factor of 100.

The KYZ type output can be wired to a 2-wire or 3-wire pulse receiver (Figure 5-20). Use terminal #3 (K) and terminal #2 (Y) to wire to a 2-wire pulse receiver. Use terminal #3 (K), terminal #2 (Y), and terminal #1 (Z) for a 3-wire pulse receiver.

Normally, energy management systems utilize only two of the three wires available from a KYZ pulse initiator. In a 2-wire application, the associated pulse train looks like alternating open and closed states of a Form-A contact (Figure 5-21). The pulse resulting from using only one side of the Form-C contact is defined as the transition from OFF to ON. Figure 5-21 identifies these transitions as 1 and 2, with each representing the time when the relay changes from KZ to KY. The receiver counts a pulse at points 1 and 2.

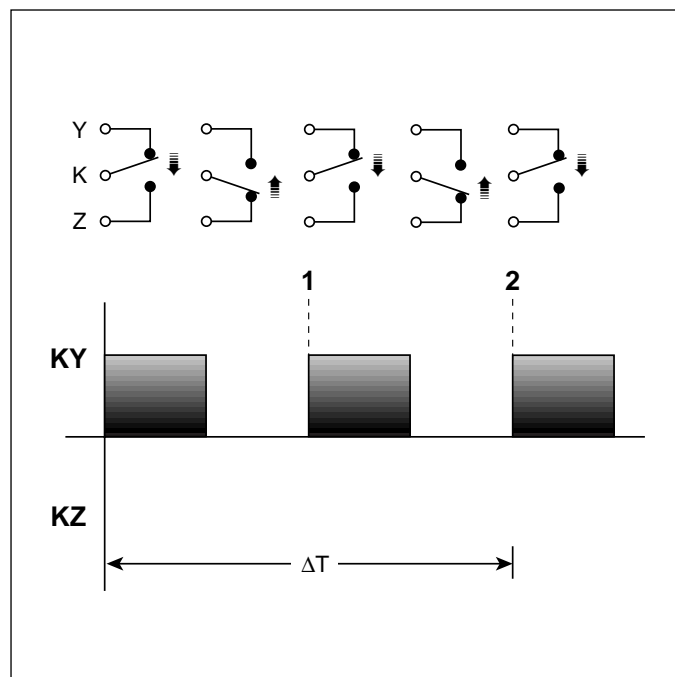

Figure 5-21 2-Wire Pulse Train

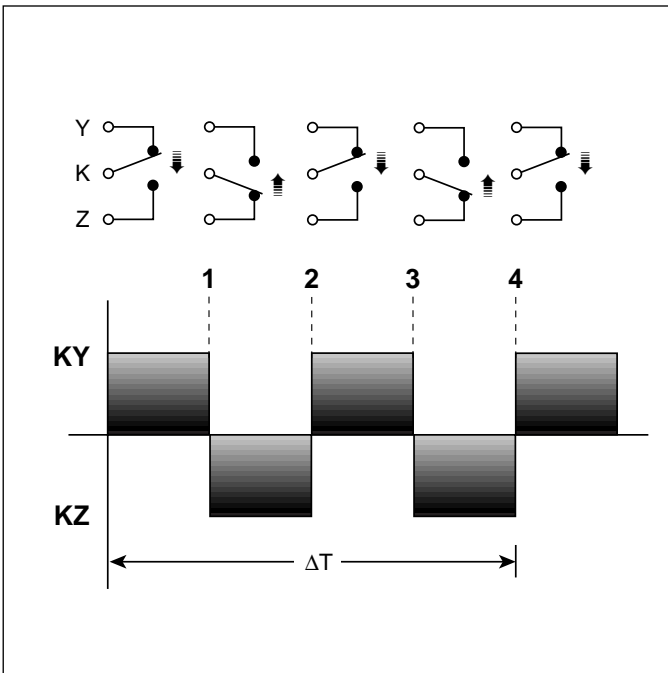

Figure 5-22 3-Wire Pulse Train

Some applications require all three wires from the pulse initiator to be wired. In a 3-wire application, the pulses are defined as transitions between KY and KZ (Figure 5-22). The transitions are identified as 1, 2, 3, and 4, with each transition representing the time when the relay changes from KY to KZ or from KZ to KY. The receiver counts a pulse at points 1, 2, 3, and 4.

5-6.4.3 EVENT/ALARM/IMPACC

Relays can be set for auto or manual reset with a release delay. Each relay can become active from any of the seven triggers that cause events, any of the three discrete inputs, or from an IMPACC command. The relay becomes active when any of the selected items occurs (any item with an asterisk next to it on the display or a checked box in IMPACC software). For example, it may be desirable to have the relay become active when any of several things happens, such as any trigger or discrete input. With auto reset selected, the relay becomes inactive when all selected items become inactive and the additional programmed delay time passes. A **0000 release time** is recommended with IMPACC control.

5-6.4.4 REVERSE SEQUENCE ALARM

Relays can be set for auto or manual reset with a release delay. Each relay can serve as a reverse sequence alarm output. On an eight cycle basis, the IQ Analyzer compares the actual phase sequencing with the rotation sequence (ABC or CBA) specified in the general setup configuration for three-phase systems. The relay becomes active immediately upon and remains active until reset manually or after the rotation is correct and the set delay has passed.

5-6.4.5 RELAY MODE OPTIONS

Each relay has a setting that allows the user to choose between MODE 1 (energize relay upon event/alarm) and MODE 2 (release relay upon event/ alarm). Neither mode is ideal for all situations. Mode 2 is ideal as an undervoltage relay while Mode 1 is ideal as an overcurrent relay. The earliest versions of IQ Analyzer only operated in Mode 2 such that the relays were normally energized, but then de-energized upon an event or loss of power to the IQ Analyzer.

NOTICE

A variety of other applications are available for the relays by OR-ing several event triggers or discrete inputs (Table 5.5). For example, a phase loss is a programmable voltage imbalance or current imbalance. Similarly, a single relay can shed upon the OR of high demand current, high demand power, maximum current, magnitude of THD, and discrete input (manual shed).

5-6.4.6 MANUAL/AUTO RESET (RESET DELAY TIME)

An additional delay is provided before returning to the inactive state. Refer to Figure 5-26.

5-7 ANALYSIS MODES

The Analysis Mode provides four different categories of detailed information:

- Trend Analysis Information
- Event Analysis Information
- Harmonic Analysis Information
- Demand Analysis Information

Analysis screens for the selected analysis category deliver detailed information concerning the system being monitored in terms relative to the selected category.

Pressing the appropriate function pushbutton F1 through F4 from the "Meter Menu" can quickly access information concerning trends, recorded events, harmonic distortion and demands of current and power (Figure 5-1). Eight lines of text can be displayed on each analysis screen. The F1 through F4 function pushbuttons are always labeled "TRND" (Trend), "EVNT" (Event), "HARM" (Harmonic) and "DEMD" (Demand) respectively in every "Meter Menu" screen. Continuous use of the "Previous Level," "Home" or "Reset" pushbuttons will exit the Analysis Mode being viewed back to the "Meter Menu" screen.

5-7.1 TREND ANALYSIS

From any "Meter Menu" screen, press the F1 (TRND) function pushbutton to access the Trend Analysis screens. These consist of time and date stamped (1 second resolution) minimum and maximum values for the parameters shown in Table 5.7.

Table 5.7 Trend Analysis Parameters

Parameter Display	Comments
Min/Max Current	<ul style="list-style-type: none"> Phase A, B, C Neutral Ground
Min/Max Voltage	<ul style="list-style-type: none"> Phase A-N, B-N, C-N Phase A-B, B-C, C-A Neutral - Ground
Min/Max Power	<ul style="list-style-type: none"> Real (watts) Reactive (vars) Apparent (VA) Phase A, B, C and System
Min/Max Power Factor	<ul style="list-style-type: none"> Displacement Apparent Phase A, B, C and System
Min/Max % and Magnitude THD	<ul style="list-style-type: none"> Current (Phases A, B, C, N) Voltage (Phase A-B, B-C, C-A) (Phase A-N, B-N, C-N)
Min/Max Frequency	<ul style="list-style-type: none"> Hz

All minimum and maximum values may be reset via the "Reset" pushbutton, discrete input or communications command. Values are updated at least once every 16 line cycles (Figure 5-23). It should be noted that Trend logging is only available via IMPACC.

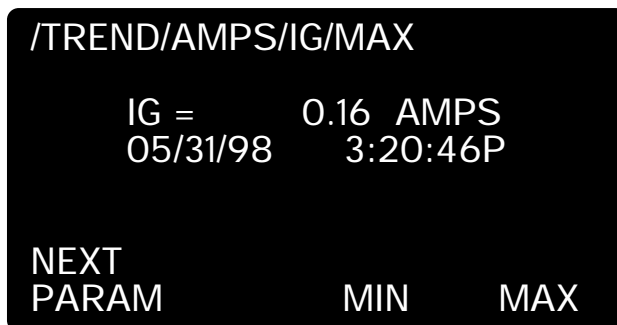

Figure 5-23 Typical Trend Analysis Screen (Ground Current Maximum)

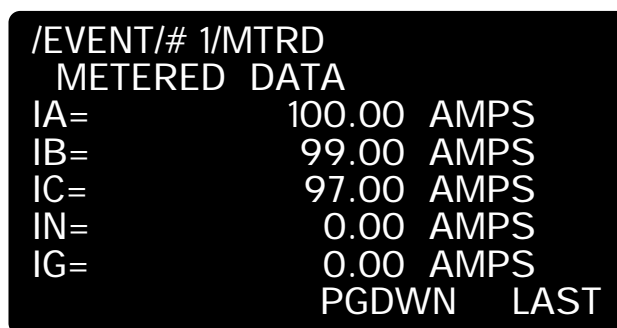

Figure 5-24 Typical Event #1 Screen

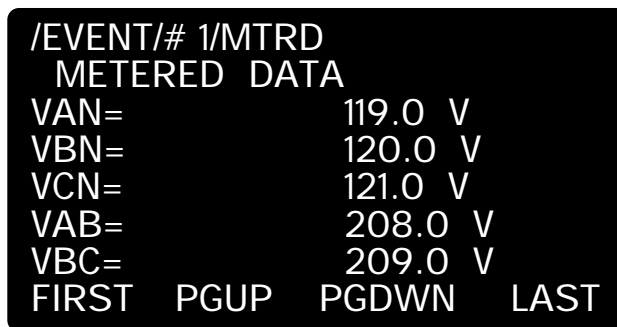

Figure 5-25 Typical Metered Event Voltage Screen

Both %THD and Magnitude THD are offered to maximize the amount of useful information available. In general, Magnitude THD is more informative than %THD. While a 10% harmonic current is 10 amperes when drawing 100 amperes, the percentage often rises when the current draw falls. For example, at night linear loads may be shut down, leaving only harmonic generating loads (the %THD rises). Conversely, the maximum magnitude THD occurs during high demand periods. In summary, the maximum %THD and Magnitude THD occur at different times.

5-7.2 EVENT ANALYSIS

From any “Meter Menu” screen, press the F2 (EVNT) function pushbutton to access the Event Analysis Screens (Figures 5-24 and 5-25). The following data can be displayed for up to ten event conditions:

- Description, date and time of event
- Currents, voltages, power readings, frequency and %THD at time of event
- All current and voltage distortion information available at time of event

Event data is stored in non-volatile memory. If a reset threshold is programmed, the duration of the event is also displayed. With the IMPACC communications option and Series III software, wave forms and harmonic profiles can be displayed on a personal computer.

Events can be triggered by up to seven Event Conditions shown in Table 5.8. The seven event triggers and the setting for the number of pre-trigger cycles, which ranges from 0 to 6, are very powerful settings. During programming, the present trigger setting is displayed for each of the seven triggers.

Each trigger causes an event which captures metered, harmonic and waveform data. Normally, one of the seven triggers should be set to manual/IMPACC so that harmonic analysis and waveform capture are available upon request. Most triggers have a trigger threshold, reset threshold, manual reset option, and delay time. However, discrete input manual/IMPACC triggers and min/max have neither thresholds nor delay settings.

NOTICE

If no time delay is programmed, any disturbance lasting 2 cycles (less if the magnitude is sufficient to effect rms readings) will trigger a voltage disturbance event/ alarm.

Refer to Figure 5-26 for a graphical representation of IQ Analyzer’s handling of setting driven alarms. When the trigger threshold has been satisfied for the required trigger delay time, the IQ Analyzer captures all waveforms and records the date and time. The event is active until the reset threshold is satisfied. The IQ Analyzer clears the event and records the date and time. Following the event, the associated relay remains active for the reset delay time.

Table 5.8 Event Conditions

Condition	General Parameter Display	Specific Parameter Display
Voltage Disturbance	Undervoltage/sag or dip	Any Voltage L-L Any Voltage L-N
	Overtoltage/swell	Any Voltage L-L (100-150%) Any Voltage L-N (100-150%)
Maximum Threshold Exceeded	% THD (2-1000) (or) Magnitude of THD	Current — Phase A, B, C Any Voltage L-L and L-N
	Demand	Current — Phase A, B, C and N System watts, vars, VA
	Voltage	Neutral to Ground
Minimum or Maximum Threshold Exceeded	Current	Neutral to Ground
	System Power	Phase A, B, C watts, vars, VA
	Frequency	Specific
	System Power Factor	Minimum
Voltage Phase Unbalance	Voltage	Any Voltage L-L and L-N
Current Phase Unbalance	Current	Current — Phase A, B, C
Discrete Input Energized	Input	Input 1, 2, 3
IMPACC Command	Command	Through Communications Port
Min/Max Update	Min/Max	Any combination of min/max current, voltage, THD etc.

5-7.2.1 TRIGGER THRESHOLD

The trigger threshold is the level at which the trigger causes an event. Usually a threshold is shown in actual units (amperes, volts, watts etc.) and as a RAW number. The RAW number is the representation of the setting as stored in the IQ Analyzer’s memory. While it may be tempting to use a formula to determine what RAW number corresponds to a specific threshold, the best approach is much simpler. Merely adjust the RAW number until the real unit threshold value is desirable. For example, with a CT ratio of 5000:5, a RAW number of 40

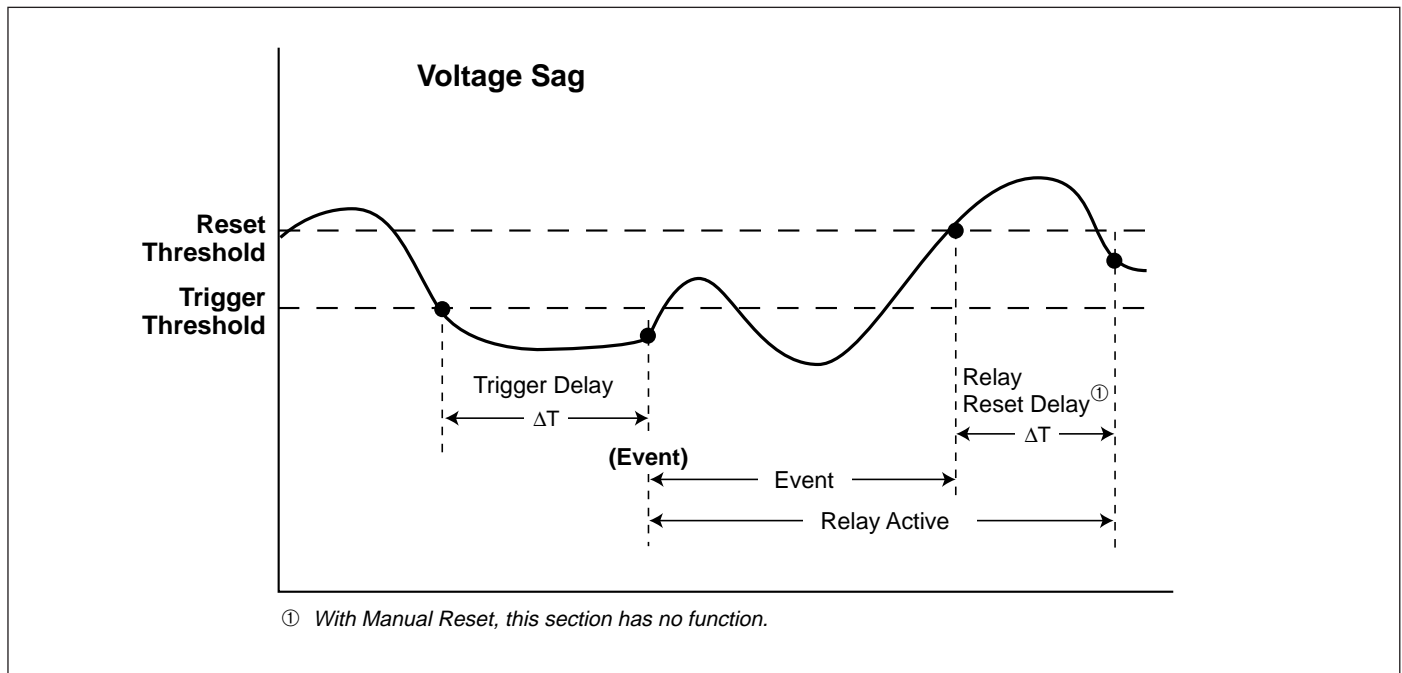

Figure 5-26 Representation of IQ Analyzer's Handling of Setting Driven Alarms

is 100 amperes and 41 is 102.5 amperes. Continuing with this example, if it is desirable to have a magnitude THD trigger on I_a of 250 amperes, it would be found that the RAW number of 100 corresponds to the desired 250.00 ampere setting. Thresholds whose values are naturally apparent or a percentage, such as %THD, power factor, % current unbalance, % voltage unbalance, and frequency, are shown only as a RAW number.

NOTICE

For a more detailed discussion of RAW number, refer to the glossary in the back of this document.

5-7.2.2 RESET THRESHOLD

The reset threshold makes the trigger ready for another event. This setting applies to both the auto reset only and manual reset. Like the trigger threshold, there is a value in actual units and a RAW number. When the selected measurement is below the reset threshold, the trigger threshold is enabled; otherwise, no event is recorded.

5-7.2.3 MANUAL/AUTO TRIGGER RESET

The option of manual reset that locks the trigger such that the resulting event cannot be overwritten by a subsequent event. The **auto reset selection is the suggested default** such that as many as the most recent 10 occurrences of the event can be viewed.

To use the manual reset (locked-first-occurrence), delete any locked events for that trigger first. That is, the trigger only occurs when the value is below the reset threshold, the value transitions through the trigger threshold, and no locked event exists of that trigger number.

5-7.2.4 TRIGGER DELAY TIME

The delay time specifies how long the trigger threshold must be exceeded before causing an event. Depending upon the trigger selection, the delay is either 0.1 to 60 seconds (0.1 second increments) or 0 to 3600 cycles (2 cycle increments). Note that the delay can only be zero for voltage disturbance. For other triggers the threshold must be exceeded for at least two comparisons before an event occurs. Comparisons occur every 2 cycles for voltages and every 8 cycles for currents, power, power

factor, frequency, and THD. While any delay can be entered within the range, not all are appropriate. For example, Total Harmonic Distortion (THD) is an attribute associated with a steady state distortion, harmonic distortion implying a periodic waveform. While updates of THD occur every 8 cycles, a delay in the order of seconds is more appropriate.

5-7.2.5 TRIGGER SETTINGS

The following list of settings are highlighted as potential triggers along with their settings. **Keep in mind that each trigger, where appropriate, has a list of additional settings for trigger threshold, reset threshold, manual/auto reset, and delay just discussed.**

5-7.2.5.1 %THD

On an 8 cycle basis, this trigger takes a snapshot when the entered percentage is exceeded. The raw threshold value is stored as a percentage. This is the most useful for voltages because the %THD of the voltage increases as the voltage sags. That is, the %THD of the voltage is highest when the power quality is at its worst. The parameter options include:

- Ia, Ib, Ic, In
- Van, Vbn, Vcn, Vab, Vbc, Vca
- Worst of Ia, Ib, Ic
- Worst of Van, Vbn, Vcn
- Worst of Vab, Vbc, Vca

5-7.2.5.2 MAGNITUDE THD

This trigger operates on an 8 cycle basis. It is much more useful for currents than %THD. The problem with triggering on a %THD current is that the percentage may rise when the overall current falls. For example, at night when large linear loads are shut down and only fluorescent lighting remains, the overall current is less but the %THD has increased. Conversely, the magnitude THD for current is largest under when the power quality is at its worst. That is, one is more interested in when the harmonic current exceeds 1/10 of the rated current (100 amperes in a 1000 ampere system) rather than 10% of the fundamental current which varies continuously. The parameter options include:

- Ia, Ib, Ic, In
- Van, Vbn, Vcn, Vab, Vbc, Vca
- Worst of Ia, Ib, Ic
- Worst of Van, Vbn, Vcn
- Worst of Vab, Vbc, Vca

5-7.2.5.3 MINIMUM

This trigger operates on an 8 cycle basis. While the trigger may be set for various currents and powers, it is most useful as a trigger for the displacement power factor or apparent power factor. For example, a trigger may occur as the power factor becomes leading, which indicates too much system capacitance. Ia, Ib, Ic, System (watts, vars, VA, PF displacement, PF apparent).

5-7.2.5.4 MAXIMUM

On an 8 cycle basis, this trigger captures an event when the trigger threshold for the specified current, power or power factor is exceeded. For example, a trigger may occur as the power factor drops to an unhealthy level. Ia, Ib, Ic, In, Is, Vns, System (watts, vars, VA, PF displacement, PF apparent).

5-7.2.5.5 MAXIMUM DEMAND

This trigger monitors the demand current and powers at each demand subinterval. Note that the current demands update at each current demand interval. The power demands update at each window interval or subinterval, the first of either the IQ Analyzer's internal timer or a sync pulse input (Figure 6-7 and discrete input #1). For example, a sliding demand window with 15 intervals and a subinterval period of 1 minute would update each minute giving the average power over the past 15 minutes. **Setting the trigger threshold with a sliding demand window provides an opportunity to alarm and shed loads several minutes before utility limits will be exceeded.**

As a definition, the **demand interval** is the number of minutes in the average calculation. The **subinterval** is the number of minutes between updates. Ia, Ib, Ic, Iavg, System (watts, vars, VA).

5-7.2.5.6 VOLTAGE DISTURBANCE (SAG OR SWELL)

On a 2 cycle basis, this trigger detects either a three-phase voltage sag or swell (undervoltage or overvoltage) with a trigger delay time of 0 to 3600 cycles (Figure 5-27). A trigger occurs for a sag when any of the three-phase line-to-line or line-to-neutral voltages drops below the trigger threshold. When the measured value recovers beyond the reset threshold, the trigger threshold is enabled for a subsequent sag. VLN, VLL.

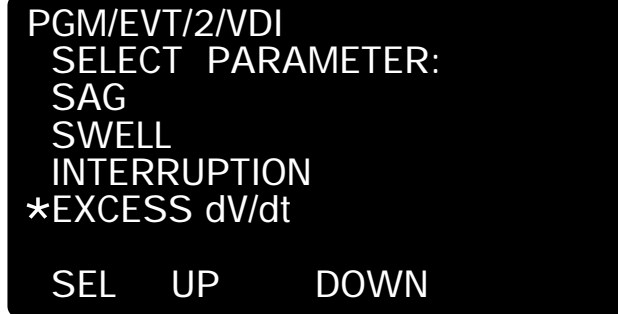

Figure 5-27 Typical Event Voltage Disturbance Screen

5-7.2.5.7 VOLTAGE DISTURBANCE (INTERRUPTION OR EXCESS DV/DT) - IQA-6200 SERIES ONLY

On a sample by sample basis (32 times per cycle), these triggers detect non-sinusoidal voltages. The intent is to detect poor connections and extreme transients due to lightning or the switching of power factor correcting capacitors while ignoring steady-state distortions.

An interruption trigger occurs when consecutive samples are too close to zero. When sampling a pure Sine wave at 32 times per cycle, it would not be expected to have consecutive samples that are less than 10% of the peak voltage.

An Excess dV/dt trigger occurs when consecutive samples are too far apart. When sampling a pure Sine wave at 32 times per cycle, it would not be expected to have consecutive samples that differ by more than 20% of the peak voltage.

Both the Interruption and Excess dV/dt triggers have internally fixed thresholds that are programmable. These triggers also operate with an auto reset and no delay (neither will create a locked event that cannot be overwritten). Because an individual sample can cause a trigger, the Interruption and Excess dV/dt triggers are much more sensitive than the other triggers within the IQ Analyzer, and some of the recorded events may not be very interesting. The intent, therefore, is not to alarm but to provide waveform information from hard to find events.

Figure 5-28 is an example of a transient captured by the IQ Analyzer at the incoming main, as seen with Waveform Display Software. In this case an internal current transient from capacitor switching causes the voltage disturbance. The same waveforms are available at the IQ Analyzer 6200 Series face.

5-7.2.5.8 FREQUENCY DEVIATION

On an 8 cycle basis the frequency is compared to the system frequency setting (paragraph 5-5.2). An event is triggered when the measured frequency deviates from

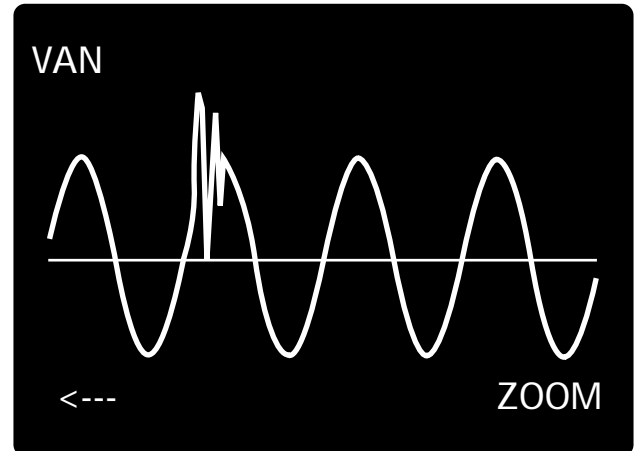

Figure 5-28 Typical Transient Waveform Display on IQA-6200 Series

nominal by the number of specified Hz.

5-7.2.5.9 CURRENT UNBALANCE

This trigger applies to a three-phase system only. On an 8 cycle basis, the rms currents of the three phases are compared. An event is triggered when the percentage difference between the largest and smallest of the three, relative to the average, is greater than the percentage specified by the setting.

5-7.2.5.10 VOLTAGE UNBALANCE

This trigger applies to a three-phase system only. On a 2 cycle basis, the rms voltages of the three phases are compared. An event is triggered when the percentage difference between the largest or smallest of the three, relative to the average, is greater than the percentage specified by the setting.

5-7.2.5.11 DISCRETE INPUT

Each of the three discrete inputs can trigger an event within 2 cycles of an external contact closure.

5-7.2.5.12 MANUAL CAPTURE

In most cases, one of the seven triggers should be a manual capture that allows manual requests for waveform capture, either locally or via IMPACC.

5-7.2.5.13 MINIMUM/MAXIMUM UPDATE

This trigger is not threshold specific like most of the other triggers. Instead, an event is triggered when recorded 8 cycle extremes are exceeded. A menu for this trigger allows the user to select any of min/max voltage, min/max current, min/max power factor, min/max power and frequency, and min/max THD. Any combination of the five can be selected. For example, to trigger events upon extreme voltage or THD conditions, select min/max voltage and min/max THD using the Function pushbuttons (soft keys). Upon the reset of min/max values, the IQ Analyzer records an event and several more events in the first few minutes. As new extremes are detected, new events are captured with decreasing frequency. Normal extremes are likely to be captured after a day or week of operation. Any further recorded events are the extremes of interest.

5-7.3 HARMONIC ANALYSIS

From the meter screen, press the F3 (HARM) function pushbutton to access the Harmonic Analysis Screens (Figures 5-29 and 5-30). Two cycles of data sampled at 128 samples/cycle and six cycles of data sampled at 32 samples per cycle are simultaneously recorded for:

- Current - Phase A, B, C, N and G
- Voltage - Phase A-B, B-C and C-A
Phase A-N, B-N, C-N and V_{NG}

/HARMONIC/VOLTS/VAB		
#	VOLTS	ANGLE-VAB
1	208.0	0.0
2	0.0	0.0
3	0.5	45.0
4	0.0	0.0
5	0.2	60.0
PGDWN		LAST

Figure 5-30 Typical Volts A-B Screen

Except for V_{NG}, which is generally smaller, magnitudes of each of the above values or their magnitude as a % of the fundamental are displayed. The displays are in odd and even multiples from the fundamental up to the 50th multiple. The phase angles relative to V_{AB} or V_{AN} are also shown. Angles are relative to V_{AB} until a line-to-neutral voltage is viewed. The angles are then relative to V_{AN}.

5-7.4 DEMAND ANALYSIS

From any "Meter Menu" screen, press the F4 (DEMD) function pushbutton to access the Demand Analysis Screens (Figures 5-31 and 5-32). The following demand data can be displayed:

- Present and Peak Currents - Phase A, B, C and Average
- Present and Peak System Power
 - Real (watts)
 - Reactive (vars)
 - Apparent (VA)

/HARMONIC/AMPS		
SELECT PHASE:		
IA		
IB		
IC		
INEUTRAL		
IGROUND		
SEL	UP	DOWN

Figure 5-29 Typical Amps Selection Phase Screen

/DEMAND		
SELECT PARAMETER:		
CURRENT	—	PRESENT DMD
CURRENT	—	PEAK DEMAND
POWER	—	PRESENT DEMAND
POWER	—	PEAK DEMAND
SEL	UP	DOWN

Figure 5-31 Demand Analysis #1 Screen

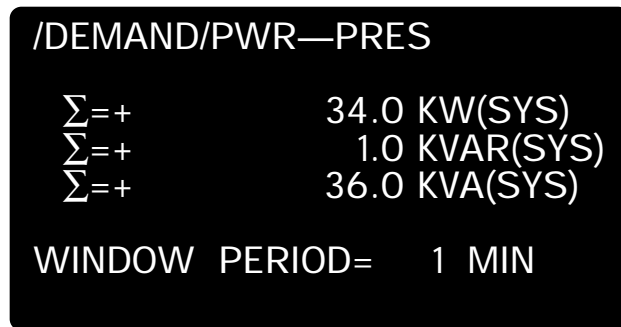

Figure 5-32 Typical Present Power Demand Screen

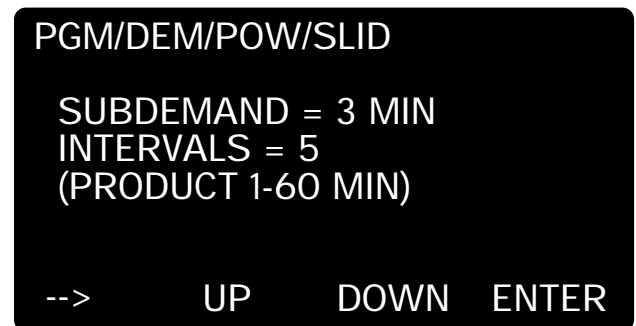

Figure 5-33 Sliding Demand Setpoints Screen

Demand windows are programmable from 1 to 60 minutes. Peak Demands for both current and system power are date and time stamped (one second resolution).

5-7.4.1 CURRENT DEMAND WINDOW (FIXED WINDOW)

Current demand, which is an average system current over time can be set to average current over a range of 1 to 60 minutes. This is known as a fixed window. For example, setting the current demand window to 15 sets the IQ Analyzer to determine the average current over the past 15 minutes and update the value every 15 minutes.

5-7.4.2 POWER DEMAND WINDOW (FIXED OR SLIDING WINDOW)

Power demand, can be a fixed window as just described, or a sliding window. That is, a 15 minute average can be obtained that is updated every 3 minutes. To accomplish this, the subdemand interval is set to 3 minutes and the number of intervals to 5 (i.e. 3 minutes times 5 intervals equals 15 minutes) (Figure 5-33).

NOTICE

The demand interval is the number of minutes in the average calculation. The subinterval is the number of minutes between updates.

The demand settings are adjustable to simulate a variety of thermal time constants. In the discussion of a sliding power demand window, an abrupt change in power achieves 60% of its final value in 9 minutes. Beyond the setting of the IQ Analyzer is the possibility of passing the power or demand power measurement to the analog outputs for analog filtering or to IMPACC for digital filtering.

5-8 COMMUNICATIONS

IQ Analyzer is an IMPACC (Integrated Monitoring Protection and Control Communications) compatible device. As such, it can be remotely monitored, controlled and programmed when equipped with the communications option. The IQ Analyzer is supplied with a communications port as standard. This permits it to have the communications option supplied from the factory or retrofitted at a later date. The communications option is achieved by mounting a small, addressable communications module, the IPONI, to the back of the IQ Analyzer (Paragraph 2-3.3 and Figure 2-5).

IMPACC is a noise immune communications system that permits communications from the IQ Analyzer to a master computer via a high frequency carrier signal over a shielded twisted pair of conductors (Figure 4-6). The shielded twisted pair of conductors can extend up to 10,000 feet without the use of repeaters. Communications between IMPACC compatible devices, such as IQ Analyzer, and the master computer is made possible by the INCOM (Industrial Communications) chip, which accounts for the system's high degree of reliability.

Functions available remotely through the communications option are:

- Monitoring and trending of displayed values and device status.
- Initiation of a Harmonic Analysis and retrieval of waveform analysis information.
- Retrieval of event information, including waveform analysis information at time of event.
- Activation of relay output contacts.
- Device programming (settings downloading).

5-8.1 IMPACC SERIES III SOFTWARE

Series III software provides the ability to monitor and record power distribution system data as it is occurring. Series III is a Microsoft Windows compatible application featuring user friendly, menu-driven screens with easy set-up and operation. Additional features include:

- System/device alarm logging and reporting
- Time/event historical data logging
- Data trending
- Information storage/retrieval by device event
- Hardware diagnostics
- Dedicated computer not required
- Security password protection
- Gateway interface for connectivity to other information networks

5-8.2 WAVEFORM AND HARMONIC PROFILE SCREENS

When an Event occurs or when given an IMPACC command, the IQ Analyzer simultaneously records eight cycles of all currents and voltages. These eight cycle waveforms may be viewed on the Wave Form Display software (Figure 5-34). Six cycles are sampled at 32 samples per cycle and two undergo high speed sampling at 128 samples per cycle. This high speed sampling is used to construct the Harmonic Profile screens and calculate K-Factor. Graphic displays show the relative magnitudes of the multiples of the fundamental frequency for both current and voltage (Figure 5-35).

5-8.3 VOLTAGE DISTURBANCE ANALYSIS

Wave Form Display software displays the first 8 line cycles of a voltage disturbance detected by the IQ Analyzer. If programmed to do so, a disturbance of up to 56 line cycles can be chained together for viewing in the Wave Form Display. The disturbance duration can also be indicated.

Since current and voltage sampling is done at the same time, the current and voltage waveforms for a given phase can be simultaneously displayed. Doing so can indicate the direction of the voltage disturbance (Figure 5-36).

5-8.4 IMPACC ENHANCED GRAPHICS

Enhanced Graphics software provides the capability to generate custom animated color graphics. For example, animated one line drawings of electrical power distribution systems, flow diagrams of processes, equipment elevation view, and other graphical representations can be

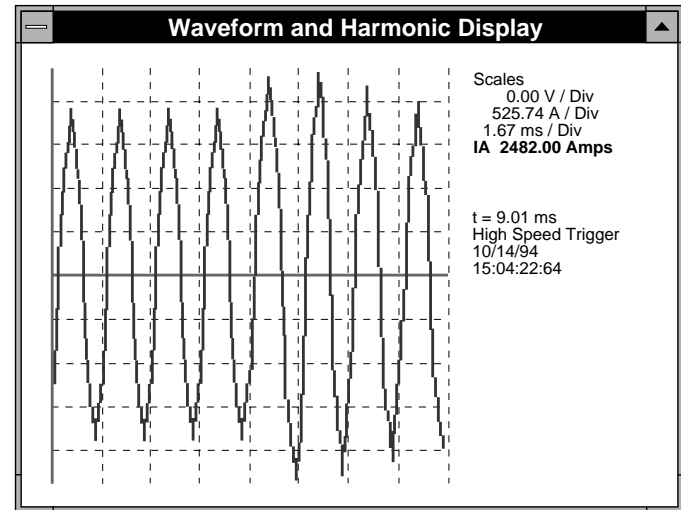

Figure 5-34 Typical Series III Wave Form Analysis Screen

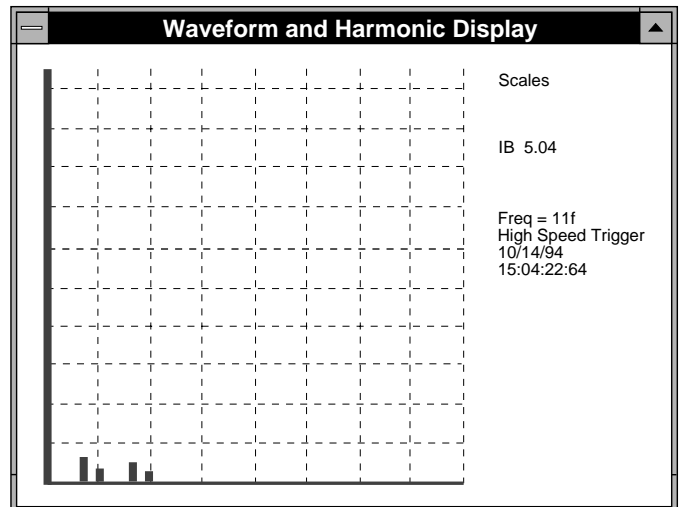

Figure 5-35 Typical Harmonic Profile

developed (Figure 5-37).

5-8.5 IMPACC CONNECTIVITY

An IMPACC network or computer running Series III software can interface with other networks. Examples of IMPACC Connectivity interfaces include:

- PLCs (Programmable Logic Controllers)
- DCSs (Distributed Control Systems)
- BMSs (Building Management Systems)
- Iconic's Genesis Software
- Intellution's FIX DMACS Software

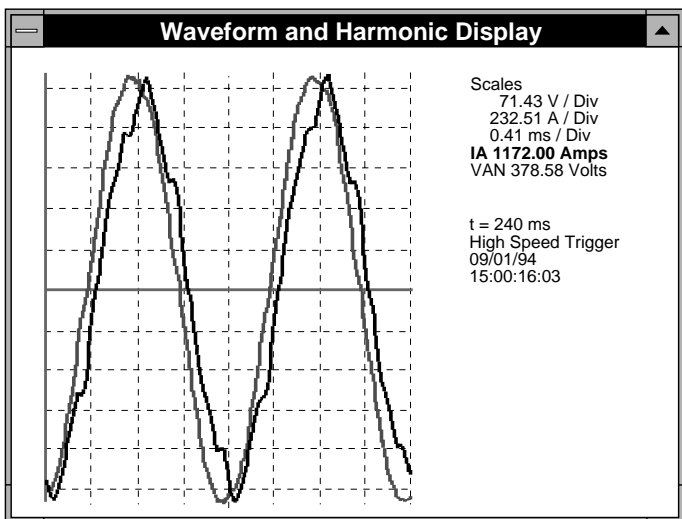

Figure 5-36 Typical Current and Voltage Simultaneous Wave Form Analysis Screen

5-9 IQ ANALYZER 6200 SERIES GRAPHIC DISPLAYS

In addition to all the features of the IQ Analyzer Series 6000 (IQA-6000), the IQ Analyzer Series 6200 (IQA-6200) provides event graphic displays from the faceplate.

Under EVNT (pushbutton F2), the IQ Analyzer displays the ten most recent events, or older events if they are locked and require a manual reset. For a particular event, the IQA-6000 Series offers two items, METERED VALUES and HARMONIC VALUES. The IQA-6200 Series offers two additional items, GRAPHIC WAVEFORM and HARMONIC SPECTRUM.

Graphic Waveform

GRAPHIC WAVEFORM displays the waveform captured as a result of an event. There is a menu of the 11 currents and voltages that were simultaneously sampled and saved at the time of the event. Upon the selection of an item, the IQ Analyzer displays the first cycle of high speed sampled data captured as a result of the trigger event. Pressing “-->” (F4 pushbutton) pans to the second cycle, and “ZOOM” (F3 pushbutton) displays the first four saved cycles (Figure 5-38). While in zoom, pressing “-->” (F4 pushbutton) pans to the second set of four cycles. In either case, pressing “<--” (F1 pushbutton) returns to the first cycle or first four cycles. The high speed sampled data is indicated with the dotted portion of the display axis. An experienced user can often determine the source of an electrical problem from the shape of the captured waveform. Pressing the “Previous Level” or “Home” pushbuttons exits the graphic waveform display.

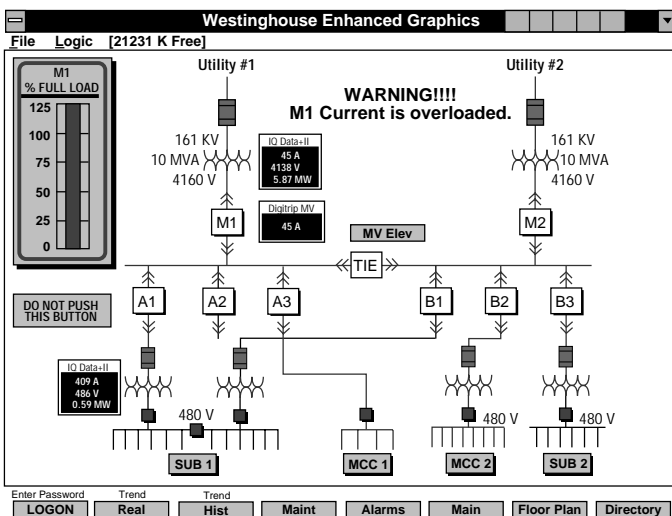

Figure 5-37 Typical Enhanced Graphics Screen

Harmonic Spectrum

HARMONIC SPECTRUM displays a graphic representation of harmonic values. An experienced user who quickly finds the largest harmonic can often identify electrical problems from the harmonic signature. The primary display shows the fundamental as 100% along with harmonics through the 21st (Figure 5-39). Pressing “-->” (F4 pushbutton) advances the display to show harmonics 22nd through 42nd. One additional press advances to show harmonics 43rd through 50th. Finally, one more press of “-->” displays the first 21 harmonics again. Pressing the “Previous Level” or “Home” pushbuttons exits the graphic waveform display.

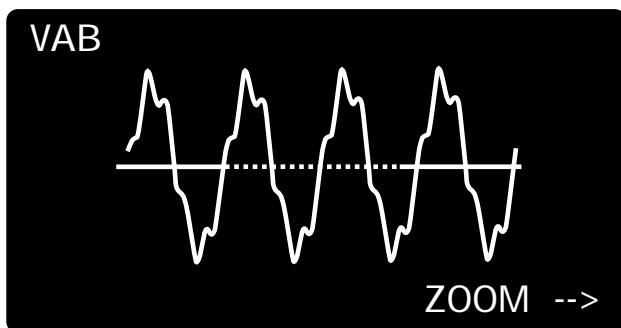

Figure 5-38 Typical Captured Waveform

5-10 RESET MODE

Pressing and releasing the “Reset” pushbutton prompts the password protected Reset Display Screen, allowing an operator to:

- Reset Peak Demand
- Reset Minimum/Maximum Values
- Rest Relay Outputs
- Reset Event/Alarm Triggers and Delete Event

Resets may also be programmed to operate through a discrete input contact(s) and the communications port.

Like the programming category screens trees in Section 6, the Reset Mode can take the form of a screens tree with a number of levels (Figure 5-40). This screens trees presents an overview of what can be accomplished while in the Reset Mode.

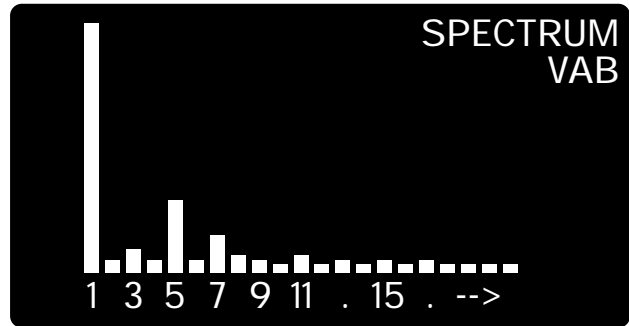

Figure 5-39 Typical Harmonic Spectrum Display

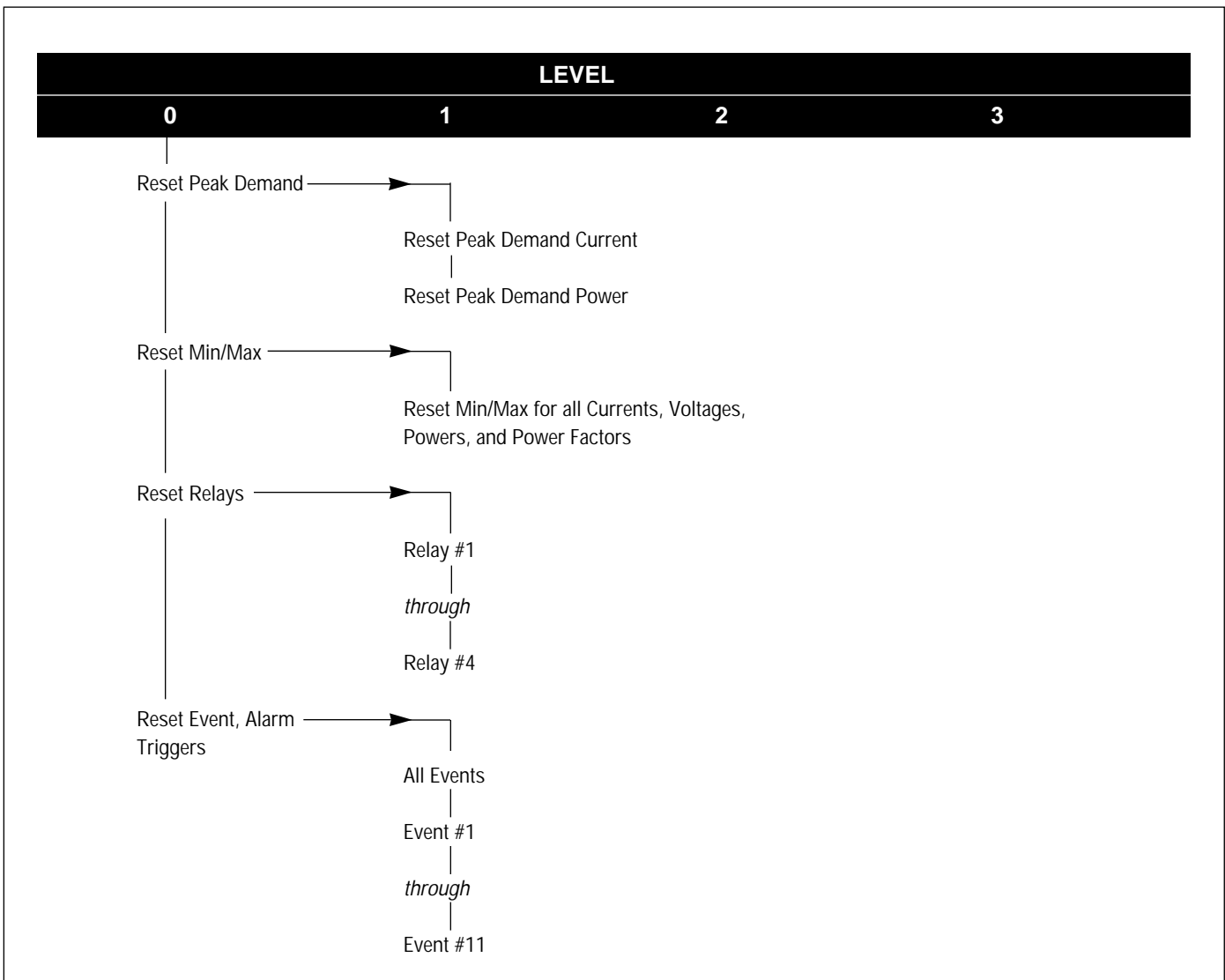

Figure 5-40 Reset Screens Tree