

WIRE DIAGRAM

DIGITRIP MV PHASE ZONE INTERLOCKING FOR MAIN-TIE-MAIN CONFIGURATION

ENGR. SKETCH
 BY D. WOOD 3/14/94
 DIGITRIP MV ZSI
 MAIN-TIE-MAIN CONFIGURATION
 SCHEMATIC AND WIRE DIAGRAM
 DWG.# 7829C72 SHEET 3

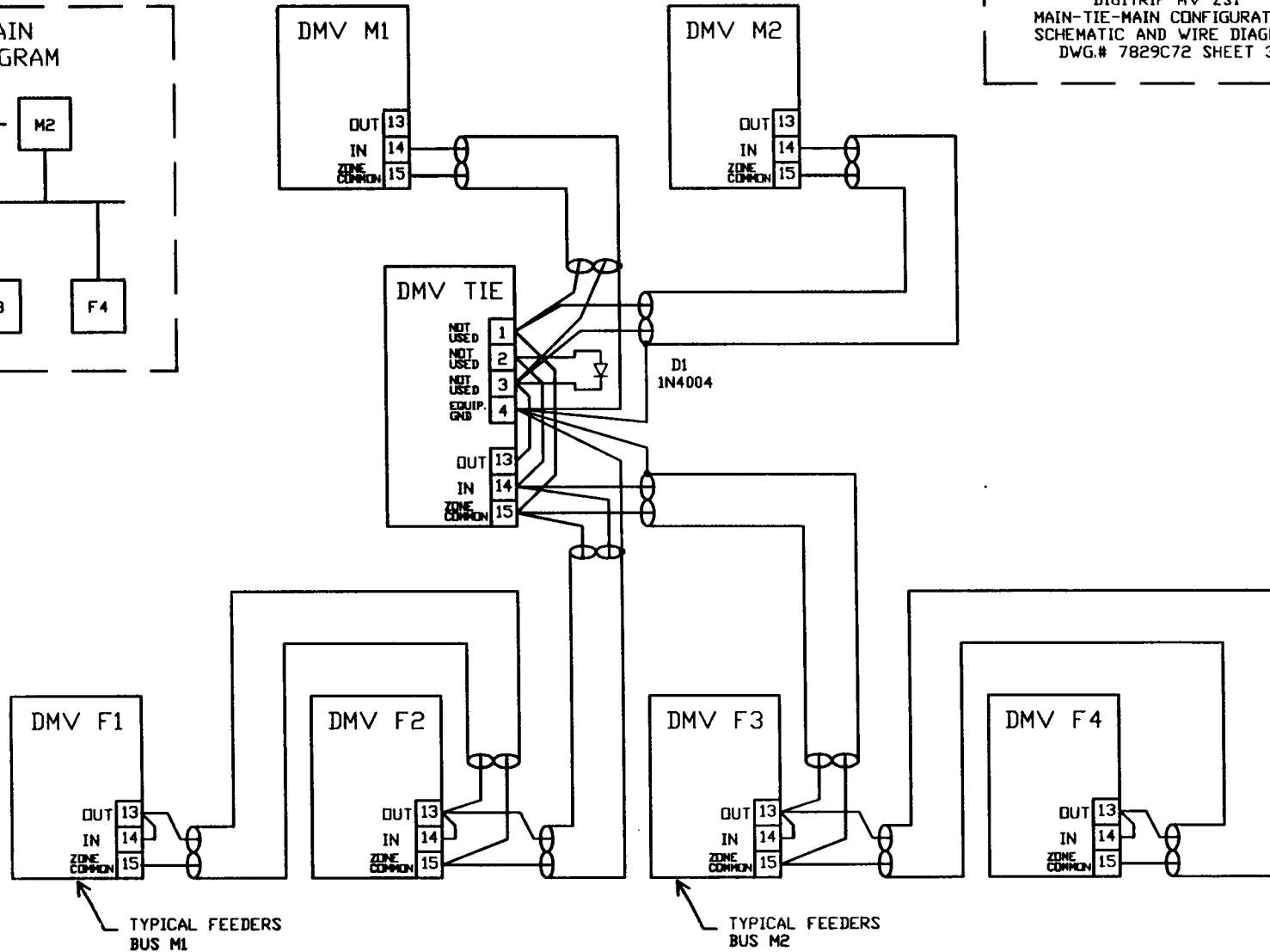
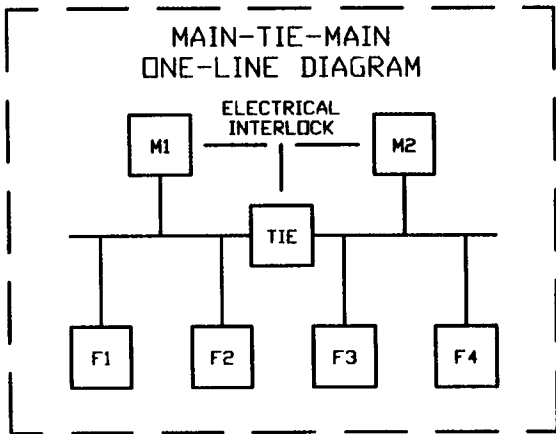

- NOTE 1: AN AUXILIARY TERMINAL BLOCK MAY BE REQUIRED FOR WIRE CONNECTIONS TO THE DMV TIE.
- NOTE 2: CABLE SPECIFICATIONS: WESTINGHOUSE CABLE CAT# IMPCABLE, STYLE# 2A95705G01 OR BELDEN 9463 CABLE FAMILY OR EQUIVALENT.
- NOTE 3: ALL WIRE SHIELDS SHOULD BE CONNECTED TO THE DMV TIE EQUIPMENT GROUND ONLY.
- NOTE 4: JUMPERS ON DMV FEEDERS (IN TO OUT) ARE USED TO PROVIDE TIME DELAY PER LONG AND SHORT DELAY TIME SETTINGS.
- NOTE 5: ONLY ONE ZONE COMMON USED. DO NOT CONNECT ZONE COMMON TO EARTH GROUND.