



## MP-3000 Motor Protection

Cutler-Hammer

1



## Motor Protection

*Award Winning Design!*

- Protects three phase induction motors of any size and any voltage
- Patented motor thermal model -field proven in over 20,000 applications world wide
- Maintenance-free microprocessor based relay design
- Keeps your motor running safely
- Recognized to UL1053 Ground Fault Protection Standard



MP-3000

Cutler-Hammer

2



## Motor Considerations

---

- Motor Importance
- Motor Characteristics
  - Horsepower rating
  - Rated Voltage, speed, service factor, etc.
- Motor starting condition
- Motor Cost
- Connected Power System

Cutler-Hammer

---

3



## Motor Failures

---

- Overload/overheating
- Electrical Short Circuits
  - Phase to ground Faults
  - Phase to phase faults
- Mechanical Failures
  - Bearings
  - Couplings

Cutler-Hammer

---

4



## Abnormal Conditions

---

- Phase Unbalance
- Single Phase
- Stall or locked rotor
- Jam
- Loss of load
- Transition

Cutler-Hammer

5



## MP3000 Catalog Numbers

---

- MP3000 Fixed case, 5 A
- MP3001 Drawout case, 5 A, no communications
- MP3002 Drawout case, 5 A, INCOM communications
- 1 Amp versions available
- MP3000 priced at \$2250 vs. 269+ at \$2837
- Drawout option for MP3000 is \$350 adder versus Multilin \$1100 adder

Cutler-Hammer

6



## MP3000 Value Packs

---

- MP3000 VPR: MP3000, URTD, RS-232 PONI and MPFO-5
- MP3000 VPI: MP3000, URTD, IPONI and MPFO-5
- Value Pack pricing competitive with 269+
- MP3000-INCOM: MP3000 plus IPONI
- MP3000-RS232: MP3000 plus RS232 PONI

Cutler-Hammer

---

7



## Motor Protection Accessories

---

- Universal RTD module (URTD)
  - One style supports up to 11 RTD inputs
  - Handles copper, nickel or platinum RTD's
  - Mounting on back of relay or separately
  - Electrical or fiber optic communications to relay
- IQDCPS
  - DC to AC power supply for DC control power applications
- IPONI for MP-3000's
- MPFO-1 - 1 meter Fiber Optic Cable for URTD/MP3000
- MPFO-5 - 5 meter Fiber Optic Cable for URTD /MP3000
- MPFO-10 - 10 meter Fiber Optic Cable for URTD /MP3000

Cutler-Hammer

---

8



## Ampgard Pricing

- MP3000 fixed case \$3,400
- Multilin
  - 269plus \$7,050
  - 369 base \$6,830
    - RTD \$400
    - Metering \$1,630
    - Back Spin \$3,220
  - 469 \$11,480

Cutler-Hammer

9



## MP-3000 Motor Relay

- Based on IQ 1000 II - the first microprocessor multifunction motor protection relay
- Development program to update the protection, hardware and user interface.
- Over 50 new features
- Drawout case option

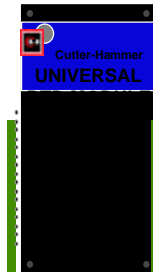

Cutler-Hammer

10



## Motor Protection

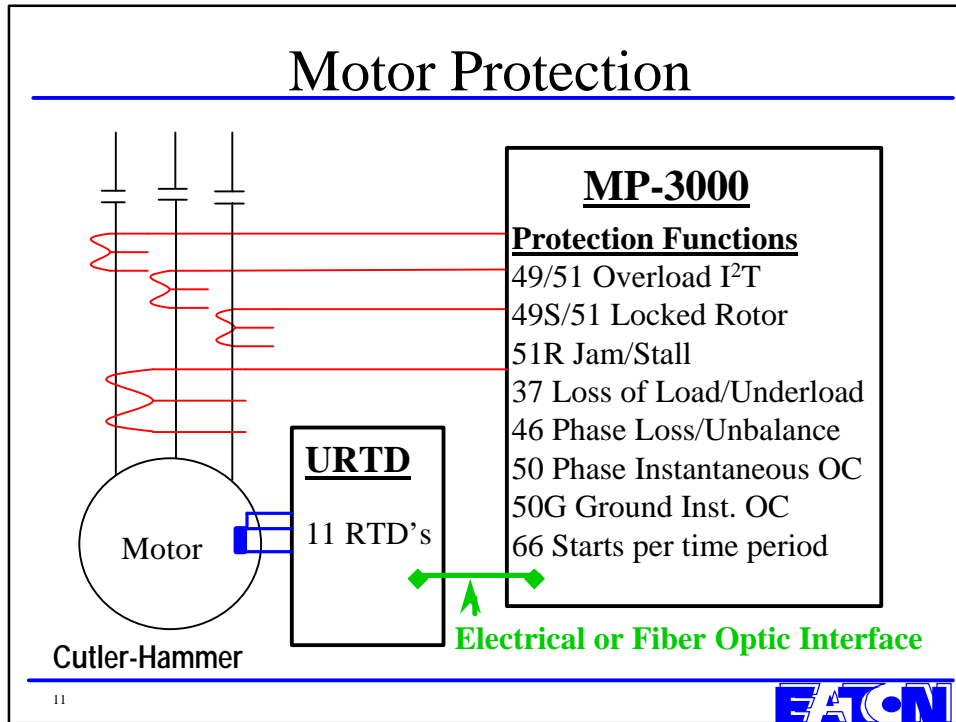

## MP-3000 Features

- Microprocessor Technology
  - Advanced protection algorithms
  - Self diagnostics
- Simple to use - On-line Help Feature
- True RMS Current Sensing
- Meets UL1053 Ground Fault Protection Standard
- Loss of voltage ride through time of 30 cycles

Cutler-Hammer

12



# Intel-I-Trip™

- Intelligent Motor Overload Protection with adaptive Characteristics
- Builds custom protection curve for each motor to insure accurate motor protection
- Uses standard information from the motor manufacture - full load amps, locked rotor current, stall time and service factor
- Accurate positive and negative sequence current measurements
- Patented, field proven motor thermal model used in over ten thousand applications world-wide
- Adaptive overload trip characteristics with RTD input based on measured motor temperatures

Cutler-Hammer

13



## MP-3000 Processor Model

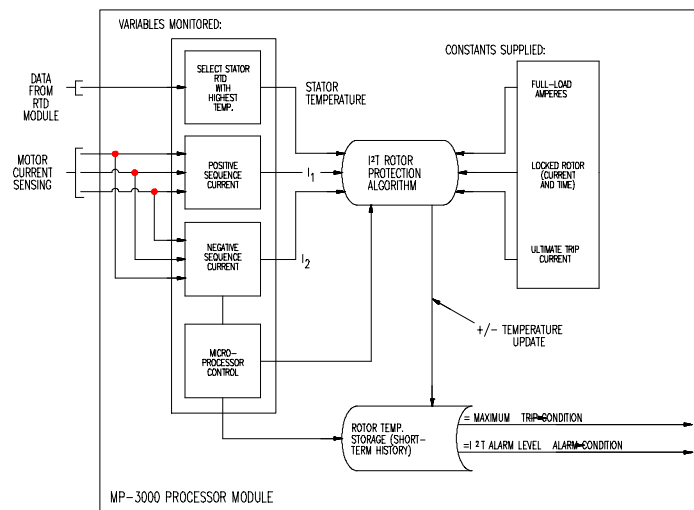

Cutler-Hammer

14



# Rotor I<sup>2</sup>t Protection

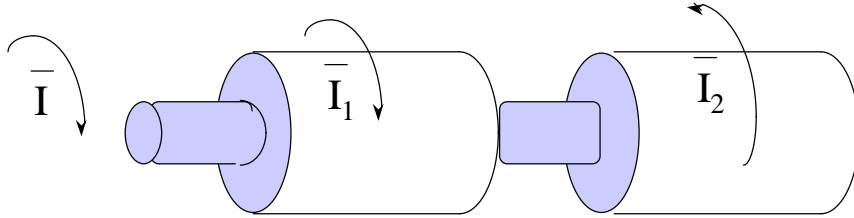

$$I = I_1 \text{ (positive sequence)} + k * I_2 \text{ (negative sequence)}$$

(Overload protection includes additional heating effect of negative sequence current)

Cutler-Hammer

15



# MP3000 I<sub>1</sub> and I<sub>2</sub> Measurements

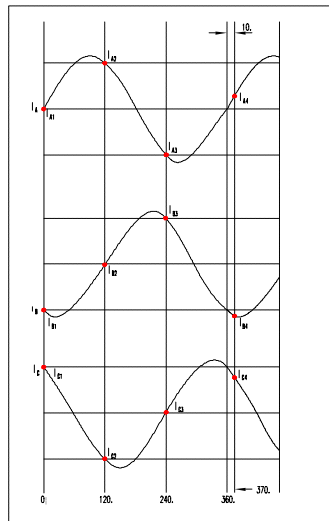

FIRST SET OF DATA		
0	120	240
I <sub>A1</sub>	I <sub>A2</sub>	I <sub>A3</sub>
I <sub>B1</sub>	I <sub>B2</sub>	I <sub>B3</sub>
I <sub>C1</sub>	I <sub>C2</sub>	I <sub>C3</sub>

SECOND SET OF DATA		
370	490	610
I <sub>A4</sub>	I <sub>A5</sub>	I <sub>A6</sub>
I <sub>B4</sub>	I <sub>B5</sub>	I <sub>B6</sub>
I <sub>C4</sub>	I <sub>C5</sub>	I <sub>C6</sub>

THREE CALCULATIONS USING FIRST SET OF DATA

$$I_1 = I_{A1} + I_{B2} + I_{C3}$$

$$I_1 = I_{A2} + I_{B3} + I_{C1}$$

$$I_1 = I_{A3} + I_{B1} + I_{C2}$$

THREE CALCULATIONS USING SECOND SET OF DATA

$$I_2 = I_{A3} + I_{B2} + I_{C1}$$

$$I_2 = I_{A2} + I_{B1} + I_{C3}$$

$$I_2 = I_{A1} + I_{B3} + I_{C2}$$

Cutler-Hammer

16



## MP 3000 New Features

- Protection operational while in program mode
- Long Acceleration time with Zero speed switch input
- Enhanced RTD monitoring and diagnostics
- Motor load shedding feature for external load control
- User configurable inputs and outputs for greater application flexibility
- Optional Quick Release draw out case
- New Armed / Disarmed Function to ensure that false tripping will not occur on installation and commissioning
- Trip or alarm option on relay failure detection
- Emergency Override resets thermal bucket and timers to permit motor starting

Cutler-Hammer

17



## MP-3000 Communications

- Requires optional IPONI or RS232 PONI
- Can Daisy Chain up to 1000 devices on INCOM LAN.
- Configure set points & set real time clock .
- Backward compatible with IQ1000 II.
- Alarm status available over INCOM.
- Event logging with date and time stamp
- *New feature* - motor starting curve data, average current vs time, over INCOM.
  - Begin 100 ms after start declaration
  - End 5 cycles after run transition or trip
  - Data points per time based on locked rotor time.
  - Sends both recorded curve and calculated thermal trip curve for margin comparison

Cutler-Hammer

18



## STARTING CURRENT PROFILE

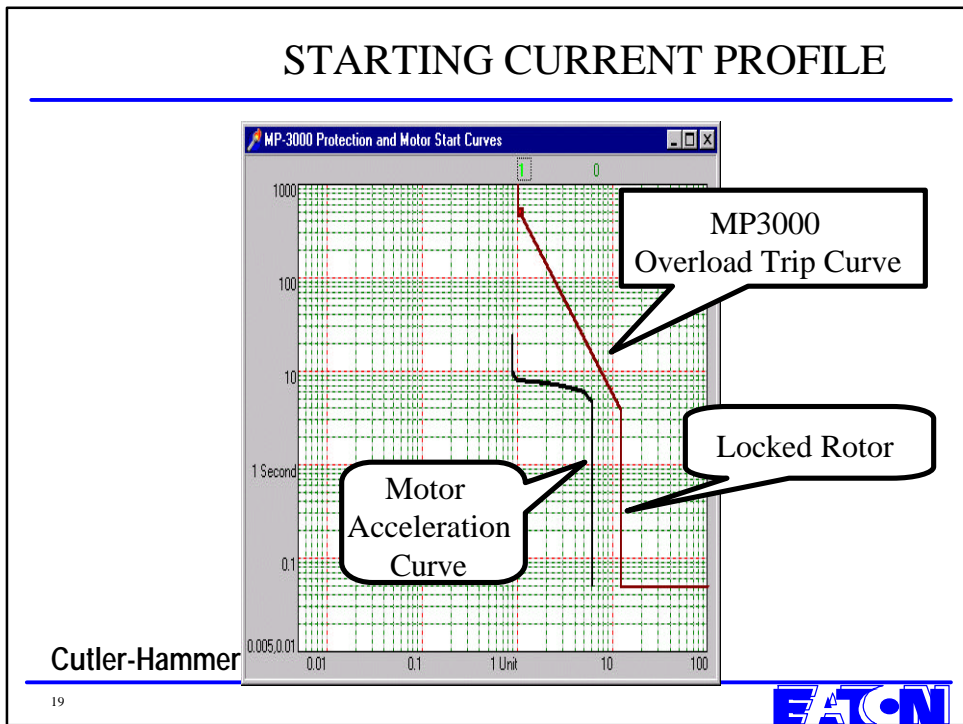

## Application: Reduced Voltage Starters

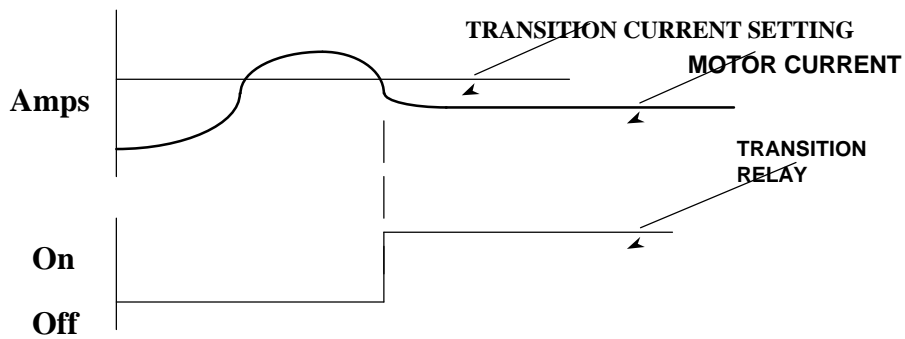

- Smooth transition from reduced voltage to full voltage based on motor starting current, time or a combination of time and/or current
- Prolonged autotransformer/reactor life by quicker removal
- Incomplete sequence verifies proper transition

Cutler-Hammer

## Motors with RTDs

---

- Separate Universal RTD Module -- Reduces installed cost by mounting module near motor
- Fiber optic connector -- Eliminates need of Copper Wire Connection to MP-3000 (or connect both for redundancy)
- One catalog number for all RTDs -- Simplifies Inventory & Ordering
- Adjusts Overcurrent Algorithm -- Reduces Nuisance Trips
- Extra RTD input -- Increases Temperature Monitoring Capability
- Stand-alone Capability -- Lowers Cost of Monitoring Temperature of Motors, Transformers, Other Equipment
- Relay will check coherency of URTD data - e.g. rate of temperature change.
- Alarming and diagnostics - will use URTD diagnostic data.
- Fail-safe behavior on communications loss

Cutler-Hammer

21



## MP3000 MMI

---

- Four interface operating modes
- Setting mode for changing settings
- Monitor mode for readout of operating conditions
- History mode for motor operation history
- Log mode for detail records of trip, alarm and start operations

Cutler-Hammer

22



## Monitor Mode

---

- Current-displays motor currents
- RTD-displays motor, bearing and load temperatures
- Motor-displays motor run and start data

Cutler-Hammer

23



## History Mode

---

- Motor Statistics
- Number of trip events
- Number of alarm events
- Permanent history
- Time and date that event occurred, or time and date counting began, is available
- The time/date start-point can be reset for the whole page

Cutler-Hammer

24



## Log Mode

---

- Log book- records 100 events with date and time stamping
- Event- detailed record of 20 trip & alarm events with date and time stamping
- Start- detailed record of the last 4 starts with date and time stamping

Cutler-Hammer

25



## Log Event

---

- Alarms and trips
  - type of trip or alarm
  - date and time of event is recorded
  - phase and ground currents at time of trip
  - % of I<sup>2</sup>T capability at time of trip
  - phase unbalance at time of trip
  - Highest RTD temp in each of 4 groups
- Up to 20 events stored

Cutler-Hammer

26



## Log Start Event

---

- Date and time of event is recorded
- Highest phase and ground current during start
- Highest phase unbalance during start
- The average current at the time of transition
- The time taken from start to current transition
- The time taken from start to actual transition

Cutler-Hammer

27



## Program Mode

---

- Motor Page
- RTD Page
- Trip Page
- Alarm Page
- Start Page
- Discrete Input Pages
- Alarm and Auxiliary Relay Output Pages
- Analog Output Page
- System Page
- Test Page
- Reset Page

Cutler-Hammer

28



## System Page

---

- Output relays individually configurable as mode 1 or mode 2 (fail-safe mode)
- Real Time Clock setting.
- 24 or 12 hour time format ; M/D/Yr or D/M/Yr date format.
- Select MP-3000 mode or IQ1000 II emulation mode for IMPACC.
- *New feature* - Armed / Disarmed Function
  - Requested for hot-plug-in replacements.
  - Unique feature to ensure that false tripping will not occur

Cutler-Hammer

---

29



## More Pages

---

### Test Page

- Ability to toggle any one of 4 outputs individually
- Force Analog output to 4, 12, or 20 ma
- Read the state of both discrete inputs

### Reset Page

- History pages can be reset in groups
- Permanent History can not be reset

Cutler-Hammer

---

30



# MP-3000 Motor Protection Hardware Connections

Cutler-Hammer

31

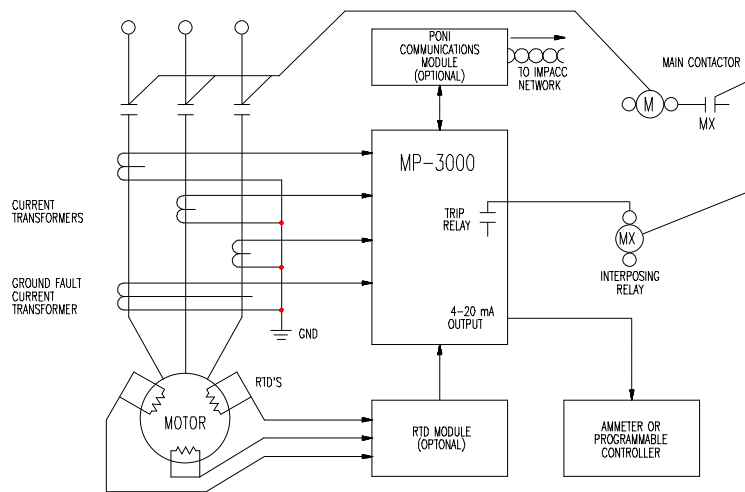

Cutler-Hammer

32





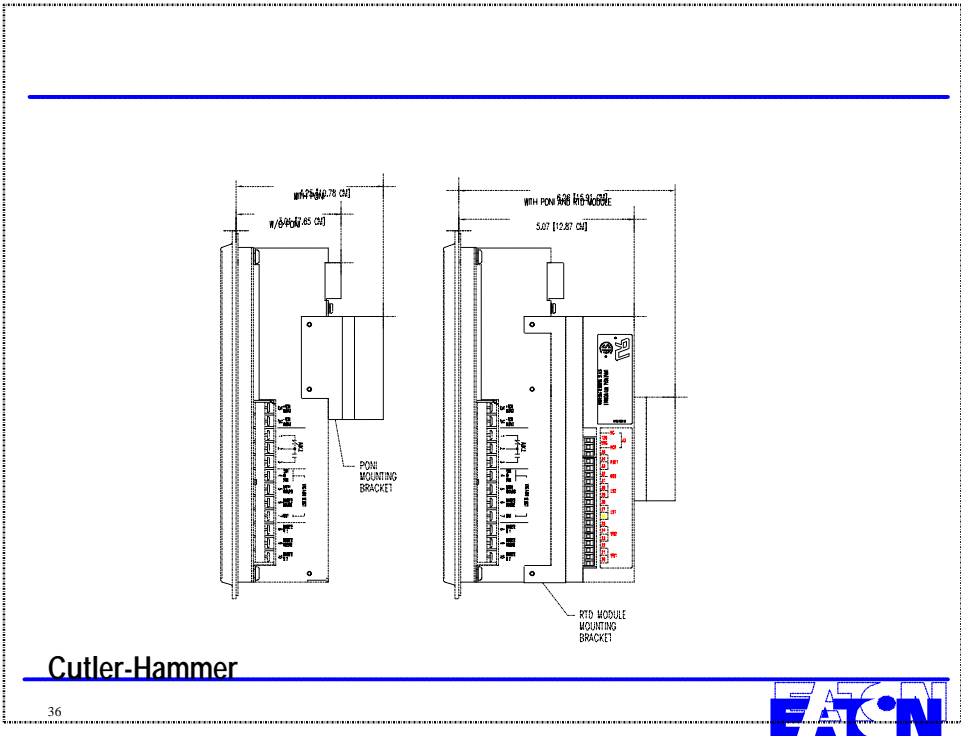
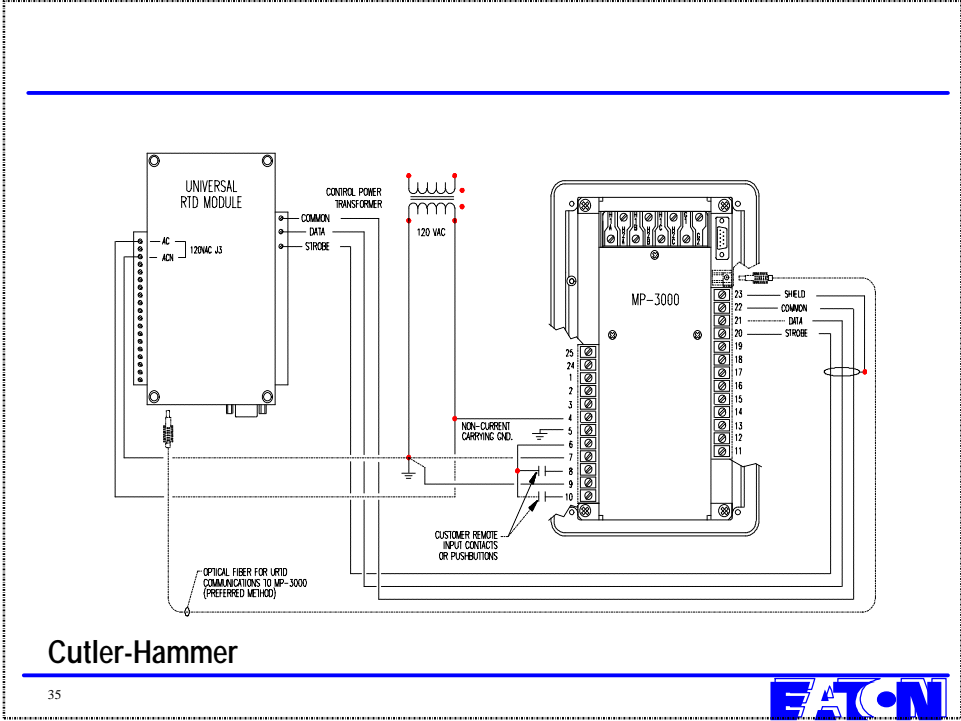

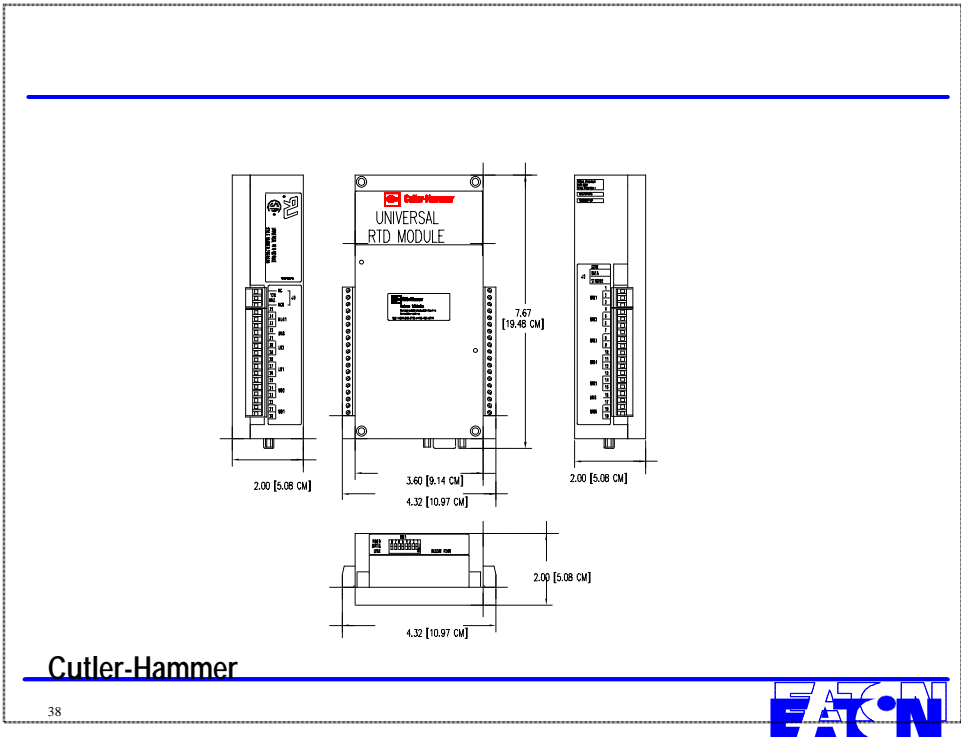
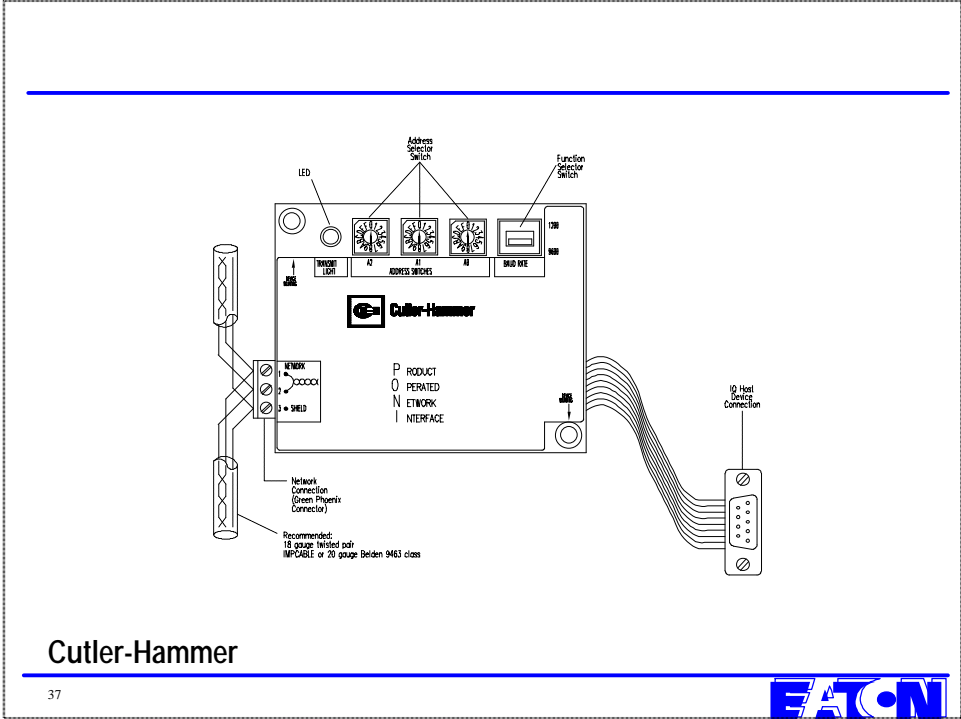

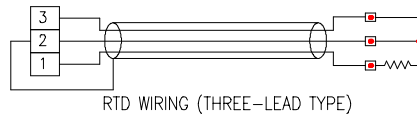
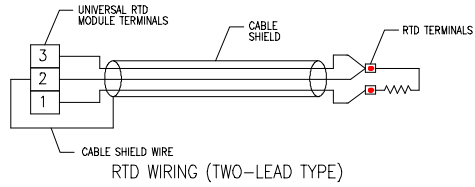

NOTES:

1. CONNECT CABLE SHIELD AT RTD MODULE TERMINALS ONLY. CUT SHIELD SHORT AT MOTOR END AND USE SHRINK TUBING OR ELECTRICAL TAPE TO INSULATE.
2. RTD'S MUST NOT BE GROUNDED AT THE MOTOR, AND NO COMMON CONNECTIONS BETWEEN INDIVIDUAL RTD'S SHOULD BE MADE AT THE MOTOR OR THE MP-3000.
3. TERMINAL 16 OR 32 ON THE RTD MODULE SHOULD BE CONNECTED TO AN EARTH GROUND.

Cutler-Hammer

39



# MP-3000

## Motor Protection

## Trip Characteristics

Cutler-Hammer

40



# Motor Current Profile

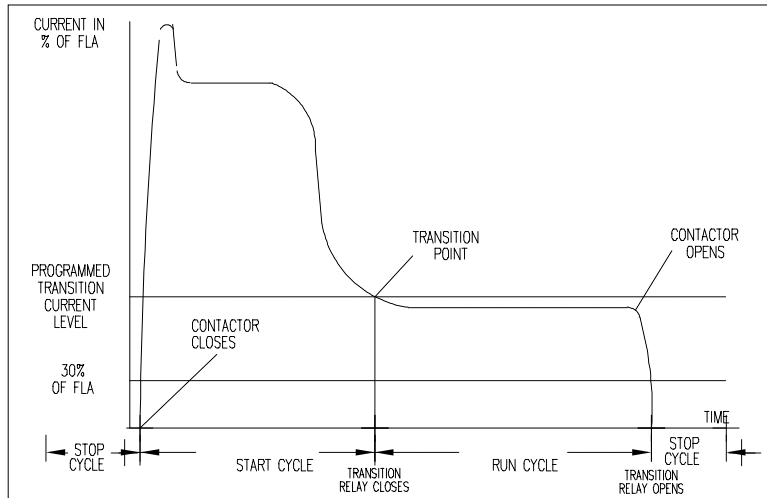

Cutler-Hammer

41



# I<sup>2</sup>t & Instantaneous

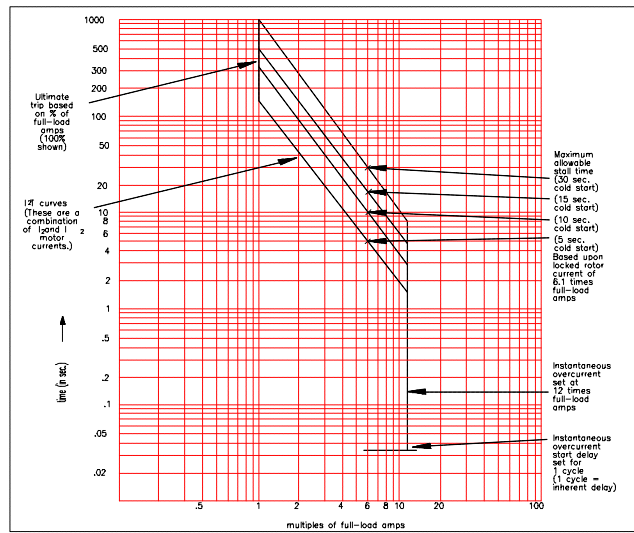

Cutler-Hammer

42



# Underload & Jam

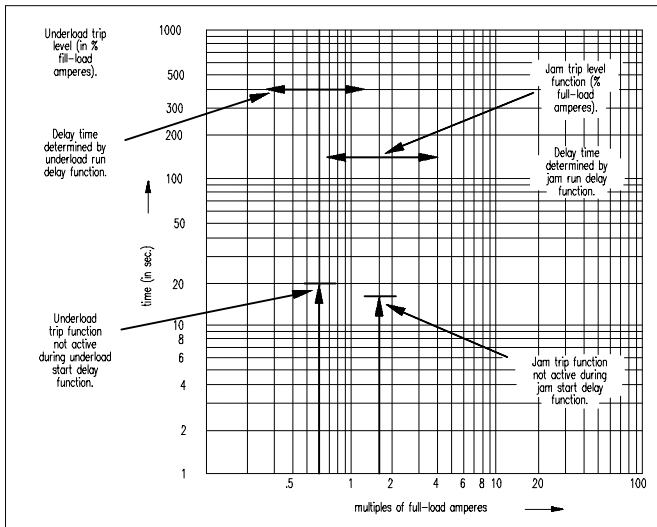

Cutler-Hammer

43



# Trip Characteristics without RTDs

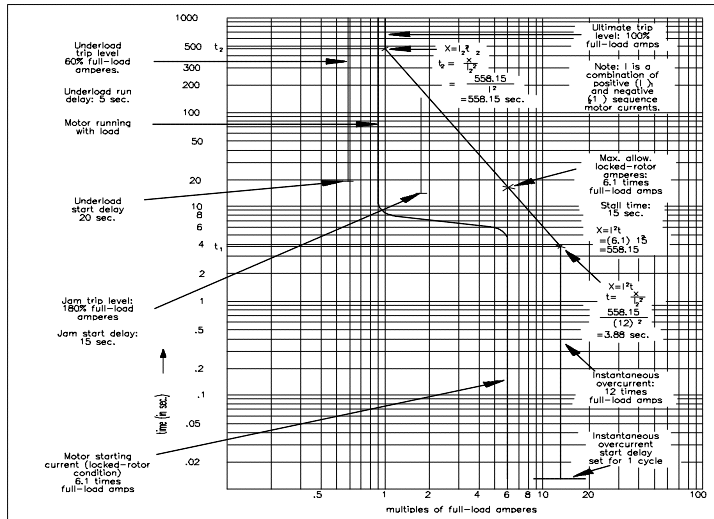

Cutler-Hammer

44



# Trip Characteristics with RTDs

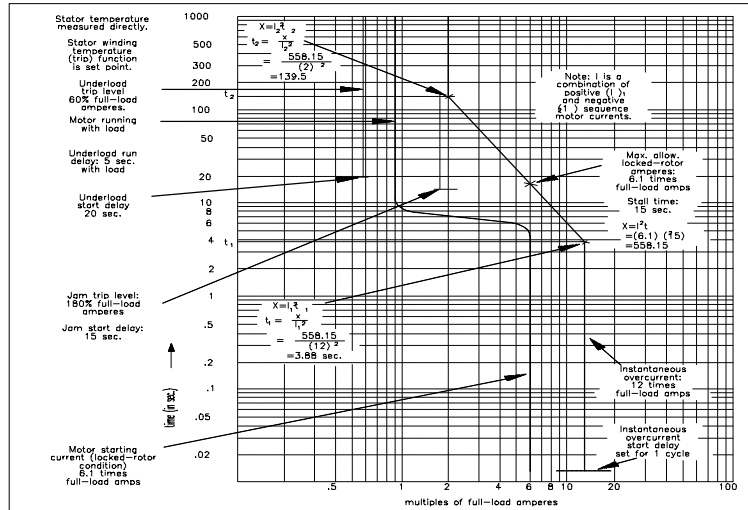

Cutler-Hammer

45



# MP-3000 Motor Protection PowerNet Screens Relay Settings

Cutler-Hammer

46



**MP-3000 Setpoints**

DeviceServer: jjen Device# 25 Description: MP3K

Firmware Version: 1.002 Comm Version: 0

Motor | RTD | Trip | Alarm | Start | DI/AO | Alarm Relay | Alarm Relay (cont.) | Aux1 Relay

Full Load Amps: 3000 Amps 3000 Amps

Locked Rotor

Current: 1200 %FLA 1200 %FLA

Time: 120 sec 120 sec

Ultimate Trip Current: 125 %FLA 125 %FLA

CT Ratio

Phase Current: 4000 : 5 4000 : 5

Ground Current: 4000 : 5 4000 : 5

Frequency: 60 Hz 60 Hz

Stator Type: Reversing Reversing

Download File Load File Save Cancel

Cutler-Hammer

47



**MP-3000 Setpoints**

DeviceServer: jjen Device# 25 Description: MP3K

Firmware Version: 1.002 Comm Version: 0

Motor | RTD | Trip | Alarm | Start | DI/AO | Alarm Relay | Alarm Relay (cont.) | Aux1 Relay

Winding Temperature

Trip: 199 deg C 199 deg C

Alarm: 199 deg C 199 deg C

Motor Bearing Temperature

Trip: 199 deg C 199 deg C

Alarm: 199 deg C 199 deg C

Load Bearing Temperature

Trip: 199 deg C 199 deg C

Alarm: 199 deg C 199 deg C

Auxiliary Temperature

Trip: 199 deg C 199 deg C

Alarm: 199 deg C 199 deg C

Local Display: Degrees F Degrees F

RTD Diagnostics: Diagnostics On Diagnostics On

Download File Load File Save Cancel

Cutler-Hammer

48



**MP-3000 Setpoints**

DeviceServer:  Device#:  Description:

Firmware Version:  Comm Version:

Motor | RTD | Trip | Alarm | Start | D/VAO | Alarm Relay | Alarm Relay (cont.) | Aux1 Relay

<b>Ground Fault</b> Trip: 55 % Ground Current CT Ratio <input type="text" value="55 % Ground Current CT Ratio"/>	<b>Under Load</b> Trip: 90 %FLA <input type="text" value="90 %FLA"/>
Start Delay: 60 Cycles <input type="text" value="60 Cycles"/>	Start Delay: 120 sec <input type="text" value="120 sec"/>
Run Delay: 60 Cycles <input type="text" value="60 Cycles"/>	Trip Run Delay: 240 sec <input type="text" value="240 sec"/>
<b>Jam</b> Trip Current: 1200 %FLA <input type="text" value="1200 %FLA"/>	<b>Phase Unbalance</b> Trip Level: 40 % <input type="text" value="40 %"/>
Start Delay: 120 sec <input type="text" value="120 sec"/>	Start Delay: 120 sec <input type="text" value="120 sec"/>
Trip Run Delay: 240 sec <input type="text" value="240 sec"/>	Trip Run Delay: 240 sec <input type="text" value="240 sec"/>
<b>Instantaneous Over Current</b> : 1600 %FLA <input type="text" value="1600 %FLA"/>	
<b>Instantaneous Over Current Start Delay</b> : 60 Cycles <input type="text" value="60 Cycles"/>	

Download File Load File Save Cancel

**Cutler-Hammer**

49



**MP-3000 Setpoints**

DeviceServer:  Device#:  Description:

Firmware Version:  Comm Version:

Motor | RTD | Trip | Alarm | Start | D/VAO | Alarm Relay | Alarm Relay (cont.) | Aux1 Relay

<b>Ground Fault Alarm</b> : 55 % Ground Current CT Ratio <input type="text" value="55 % Ground Current CT Ratio"/>	<b>12T (Overload) Alarm</b> : 99 % of bucket <input type="text" value="99 % of bucket"/>
<b>Jam Alarm</b> Current: 1200 %FLA <input type="text" value="1200 %FLA"/>	Run Delay: 240 sec <input type="text" value="240 sec"/>
<b>Under Load Alarm</b> Current: 90 %FLA <input type="text" value="90 %FLA"/>	Run Delay: 240 sec <input type="text" value="240 sec"/>
<b>Phase Unbalance Alarm</b> Level: 40 % <input type="text" value="40 %"/>	Run Delay: 240 sec <input type="text" value="240 sec"/>

Download File Load File Save Cancel

**Cutler-Hammer**

50



**MP-3000 Setpoints**

DeviceServer: jin    Device# 25    Description: MP3K

Firmware Version: 1.002    Conn Version: 0

Motor | RTD | Trip | Alarm | Start | DI/AO | Alarm Relay | Alarm Relay (cont.) | Aux1 Relay

Starts Per Programmed Time: 10 starts    10 starts

Time for Programmed No. of Starts: 240 min    240 min

Time Between Starts: 240 min    240 min

Number of Cold Starts: 5 starts    5 starts

**Start to Run Transition**

Current Level: 300 %FLA    300 %FLA

Time: 480 sec    480 sec

Event: On Time and Current    On Time and Current

**Incomplete Sequence**

Time Out: 240 sec    240 sec

Time Start Event: On Stop to Start Trans.    On Stop to Start Trans.

Long Acceleration Time: 240 sec    240 sec

Zero Speed Switch: Zero Speed Switch On    Zero Speed Switch On

Anti Backspin Time: 240 sec    240 sec

Download    File Load    File Save    Cancel

Cutler-Hammer

51



**MP-3000 Setpoints**

DeviceServer: jin    Device# 25    Description: MP3K

Firmware Version: 1.002    Conn Version: 0

Motor | RTD | Trip | Alarm | Start | DI/AO | Alarm Relay | Alarm Relay (cont.) | Aux1 Relay

Discrete Input 1 Function: Zero Speed Switch    Zero Speed Switch

Discrete Input 2 Function: Inc. Sequence Function    Inc. Sequence Function

Analog Output Function: MAX %I2T    MAX %I2T

Download    File Load    File Save    Cancel

Cutler-Hammer

52



**MP-3000 Setpoints**

DeviceServer:  DeviceID:  Description:

Firmware Version:  Comm Version:

Motor | RTD | Trip | Alarm | Start | DI/AO | Alarm Relay | Alarm Relay (cont.) | Aux1 Relay

- Event To Activate Alarm Relay

Ground Fault:	Ground Fault Trip	RTD To Activate Alarm Relay	Motor Winding:	Motor Winding RTD Trip
I2T:	I2T Trip		Motor Bearing:	Motor Bearing RTD Trip
Jam:	Jam Trip		Load Bearing:	Load Bearing RTD Trip
Under Load:	Under Load Trip		Auxiliary:	Auxiliary RTD Trip
Phase Unbalance:	Phase Unbalance Trip			Auxiliary RTD Trip

- To Activate Alarm Relay

Starts Per Hour:  Starts Per Hour Trip

Time Between Starts:  Time Between Starts Trip

Cutler-Hammer

53



**MP-3000 Setpoints**

DeviceServer:  DeviceID:  Description:

Firmware Version:  Comm Version:

Motor | RTD | Trip | Alarm | Start | DI/AO | Alarm Relay | Alarm Relay (cont.) | Aux1 Relay

- To Activate Alarm Relay

RTD Failure:	RTD Failure	RTD Failure
RTD Comm. Failure:	RTD Comm. Failure	RTD Comm. Failure
Instant. Over Current:	Instant. Over Current	Instant. Over Current
Phase Reversal:	Phase Reversal	Phase Reversal
Incomplete Sequence:	Incomplete Sequence	Incomplete Sequence
Trip By-Pass:	Trip By-Pass	Trip By-Pass

- Trip To Activate Alarm Relay

Remote:	Remote Trip	INCOM:	INCOM Trip
Differential:	Differential Trip	Transition:	Transition Trip
Zero Speed Switch:	Zero Speed Switch		Zero Speed Switch

Cutler-Hammer

54



**MP-3000 Setpoints**

DeviceServer: jcn    Device# 25    Description: MP3K

Firmware Version: 1.002    Comm Version: 0

RTD | Trip | Alarm | Start | DVA0 | Alarm Relay | Alarm Relay (cont.) | Aux1 Relay | Aux1 (cont.)

- Event To Activate Aux1 Relay

Ground Fault:	Ground Fault Trip	Motor Winding:	Motor Winding RTD Trip
I2T:	I2T Trip	Motor Bearing:	Motor Bearing RTD Trip
Jam:	Jam Trip	Load Bearing:	Load Bearing RTD Trip
Under Load:	Under Load Trip	Auxiliary:	Auxiliary RTD Trip
Phase Unbalance:	Phase Unbalance Trip	Load Shed:	

- To Activate Aux1 Relay

Starts Per Hour:	Starts Per Hour Trip	Pick Up Current:	150 %FLA
Time Between Starts:	Time Between Starts Trip	Drop Out Current:	148 %FLA
		Delay in 1/10 sec:	50

Download    File Load    File Save    Cancel

Cutler-Hammer

55



**MP-3000 Setpoints**

DeviceServer: jcn    Device# 25    Description: MP3K

Firmware Version: 1.002    Comm Version: 0

Alarm | Start | DVA0 | Alarm Relay | Alarm Relay (cont.) | Aux1 Relay | Aux1 Relay (cont.) | Aux1 (cont.)

To Activate Aux1 Relay

RTD Failure:	RTD Failure	RTD Failure
RTD Comm. Failure:	RTD Comm. Failure	RTD Comm. Failure
Instant. Over Current:	Instant. Over Current	Instant. Over Current
Phase Reversal:	Phase Reversal	Phase Reversal
Incomplete Sequence:	Incomplete Sequence	Incomplete Sequence
Trip By-Pass:	Trip By-Pass	Trip By-Pass

Trip To Activate Aux1 Relay

Remote:	Remote Trip	INCOM:	INCOM Trip
Differential:	Differential Trip	Transition:	Transition Trip
Zero Speed Switch:	Zero Speed Switch		Zero Speed Switch

Download    File Load    File Save    Cancel

Cutler-Hammer

56



**MP-3000 Setpoints**

Device Server:  Device ID:  Description:

Firmware Version:  Comm Version:

Alarm Relay (cont.) | Aux1 Relay | Aux1 Relay (cont.) | Aux2 Relay | Aux2 Relay (cont.) | System

**Relay Mode**

Trip: Mode 2: De-energizes on Trip  
 Trip:  Aux1:   
 Alarm:  Aux2:

Display Mode  
 Time Stamps:  Date Stamps:

I2T Reset Mode:  MP-3000 Self-Test Failure Action:

Program While Running:  INCOM Comm. Trip:

Emergency Override Function:  Trip Relay Armed:

IMPACC Comm. Mode:  Relay Test Mode:

Cutler-Hammer

57

